



RLH Industries, Inc.

USER GUIDE

The leader in
rugged fiber optic
technology.

U-120 2026-0417

Serial Data DIN Fiber Link System

COMPACT, RUGGED &
TEMPERATURE HARDENED

SERIAL DATA
OVER FIBER



Serial Data DIN Fiber Link

Introduction

The Serial Data DIN Fiber Link system transports two active channels of copper serial data over fiber optic cable, allowing for both RS-232 and RS-485/422 to be used at the same time. Fiber optics not only provide long distance communication up to 74 mi. (120km), but also provide immunity to EMI/RFI and transient surges. This is ideal for extending serial data communications over long distances, or near large electrical equipment where resistance to EMI is desired.

The system supports serial data rates from 50 bps to 921.6kbps, and has an auto-sensing feature that eliminates the need to manually set serial data rates. The included Pull High / Pull Low rotary dials allows for fast and easy biasing adjustment.

A comprehensive set of LEDs on the front panel indicate power status, fiber status, and serial data activity. Powering options include standard 24-48VDC or high range DC powering of 125VDC. This rugged system also features dual redundant power inputs with a system alarm contact relay, and comes standard with DIN clip and wall mount ears.

Standard Features

- Simultaneously transmits both RS-232 and RS485/422
- Convenient LEDs for power, fiber, and serial signals
- Supports baud rates of 50 bps to 921.6 kbps baud
- ST and SC single mode and multimode fiber units available
- Extends communication up to 74 mi. (120km)
- Transparent RS-232 & RS-485/422 extension over fiber
- Supports 2 & 4 Wire RS-485 operation only
- DC power, fiber break, or system failure alarm contacts
- Rotary dials for easy impedance matching
- Selectable On/Off RS-485/422 Termination
- Rugged design for wide operating temperature is standard
- Limited Lifetime warranty

Made in U.S.A.

General Safety Practices

Intended Audience

This guide is intended for use by knowledgeable installation, operation and repair personnel. Every effort has been made to ensure the accuracy of the information in this guide. However, due to constant product improvement, specifications and information contained in this document are subject to change without notice.

Conventions

Symbols for notes, attention, and caution are used throughout this manual to provide readers with additional information, advice when special attention is needed, and caution to prevent injury or equipment damage.

The equipment discussed in this document may require tools designed for the purpose being described. RLH recommends that service personnel be familiar with the correct handling and use of any installation equipment used, and follow all safety precautions including the use of protective personal equipment as required.

Caution - Severe Shock Hazard

- Never install during a lightning storm or where unsafe high voltages are present.
- Copper wires may carry high voltages. Use caution when handling.
- Do not open the enclosure, there are no user serviceable parts.

Guidelines for handling terminated fiber cable

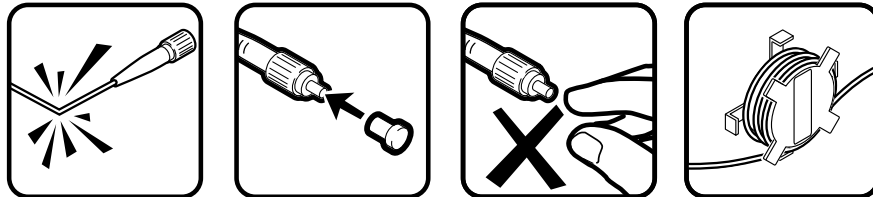

- Do not bend fiber cable sharply. Use gradual and smooth bends to avoid damaging glass fiber.
- Keep dust caps on fiber optic connectors at all times when disconnected.
- Do not remove dust caps from unused fiber.
- Keep fiber ends and fiber connectors clean and free from dust, dirt and debris. Contamination will cause signal loss.
- Do not touch fiber ends.
- Store excess fiber on fiber spools at site

Application Diagrams

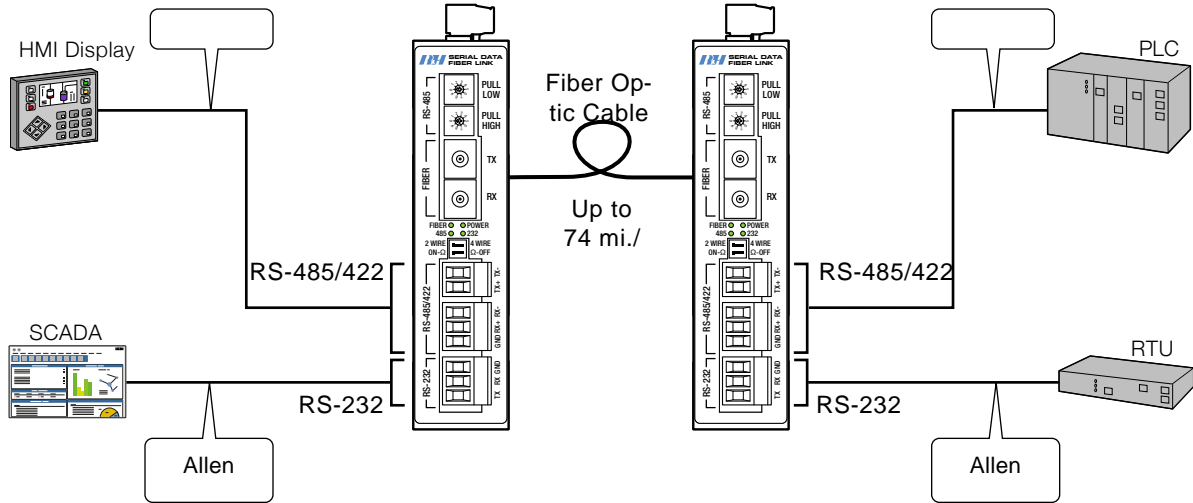

2 Channel Point to Point Application Diagram

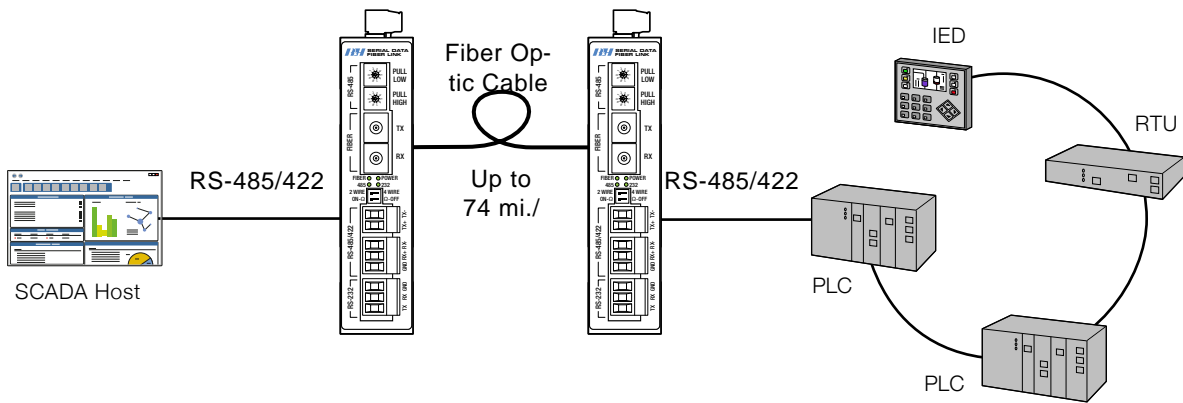

Point to Point Application Diagram

Installation

Prior to installation:

- Check for shipping damage.
- Check the contents to ensure correct model.
- Make sure you have the correct fiber type and power available.
- Have a clean, dry installation environment ready.

Required for installation:

- Suitable wall, panel, or DIN rail space.
- Local power source (24~48VDC or 125VDC depending on model).
- Flat head screwdriver for connecting wiring.
- Phillips screwdriver for attaching to wall (optional).

Physical Layout

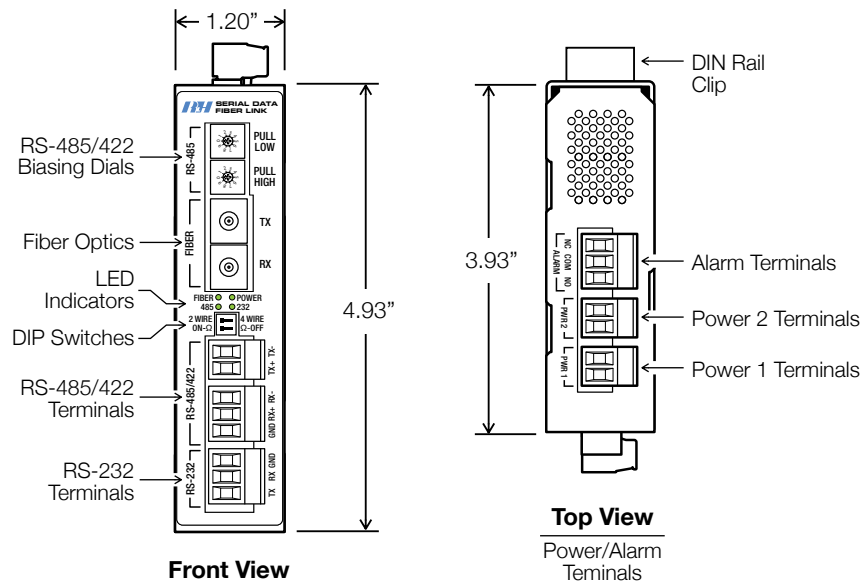

DIN Rail Mounting

The DIN clip for mounting the system is mounted onto the rear panel. Hook the DIN clip on the top flange of the DIN rail and rotate to the locked position to install. To remove, push up to depress the spring latch and rotate off of the DIN rail.

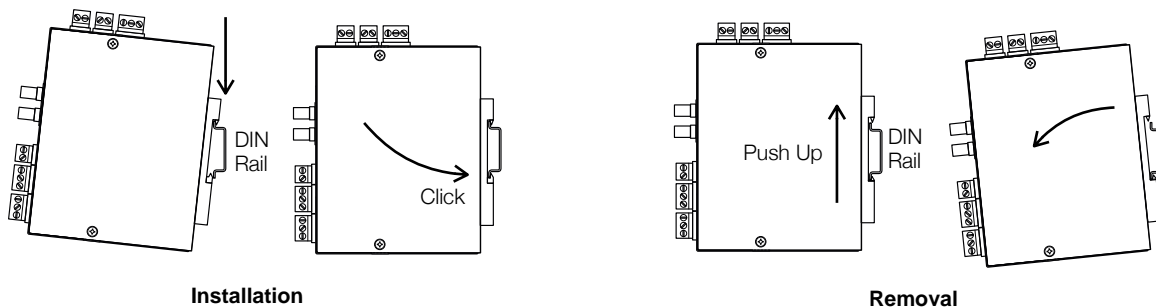

DIN Rail Mounting

Wall Mounting

The system can be easily wall mounted by attaching the provided wall mount ears and hardware. Attach the wall mount ears by following the instructions below.

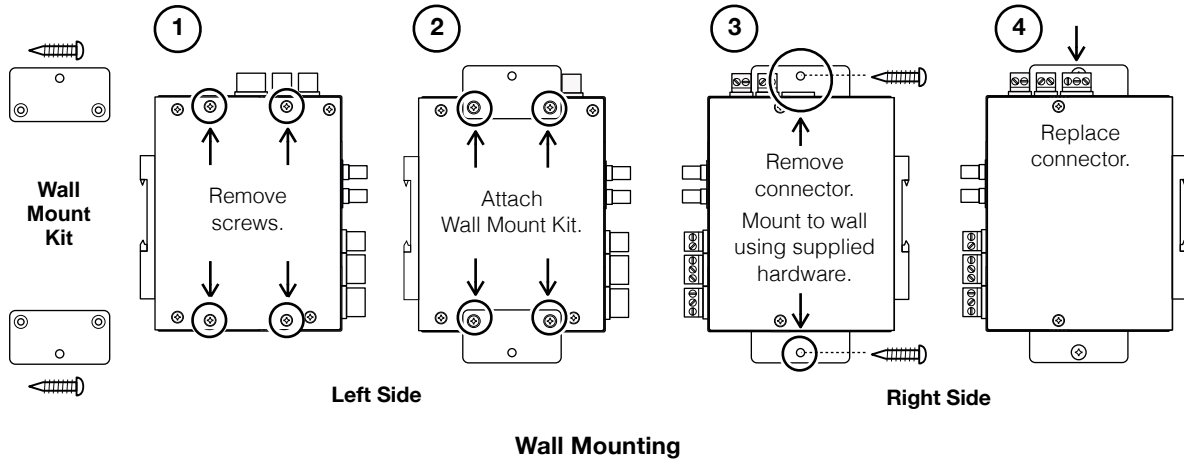

Connect Optical Fiber Cable

The optical ports may be equipped with ST or SC fiber connectors. A fiber pair is required for operation with dual fiber models, TX is the signal output side and RX is the signal input side. Single fiber models (bi-directional) combine input and output, by using different wavelengths over the fiber.

Connect fiber cables to correct TX and RX ports. On dual fiber models, Verify that the TX fiber at one module is connected to the RX port on the opposite end. On single fiber systems there will be an **A** and **B** side. The **A** side must connect to the **B** side.

Do not remove fiber cable caps until you connect fiber to the unit, watch for dust and contamination. Fiber cables should be routed loosely avoiding tight bends to prevent excessive optical loss.

RS-485/422 Biasing - Pull High and Pull Low

The rotary dials allow you to match the impedance of multi-drop & daisy chained RS-485 networks. Most RS-485 networks impedance values will vary and the more complex the system the more likely it will be necessary to tune your fiber media converter to match the impedance of the rest of the network. Each position that's indicated on the rotary dial represents a resistance value in Ohms. See the below table for the specific values for each position.

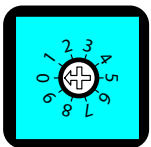

Biasing Dial

Dial	Settings									
SW2	0	1	2	3	4*	5	6	7	8	9
Pull Low Ω	0.250M (OL)	9.67K	4.9K	3.29K	0.993K	0.903K	0.828K	0.769K	0.496K	0.473K
SW3	0	1	2	3	4*	5	6	7	8	9
Pull High Ω	0.256M (OL)	10.56	5.83K	4.22K	1.949K	1.861K	1.786K	1.723K	1.458K	1.435K

***Note:** Default position is 9.

2 or 4 Wire RS-485 Selection Switch

This Dip Switch is used for the RS-485 communication bus. Set the device for 2 or 4 wire communication.

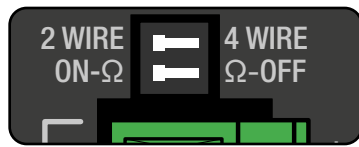

DIP Switches on Front Panel

RS-485 Dip Switch	
Setting	Switch Position
2 Wire RS-485	←
4 Wire RS-485/422	→

RS-485/422 Termination Resistor Switch

Termination resistors are sometimes needed on long copper runs or when many devices are on a RS-485/422 chain. The provided Dip Switch allows for users to easily add a 120 Ω termination resistor if determined necessary.

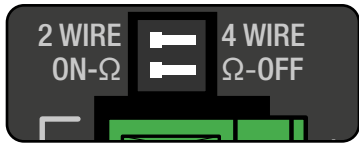

DIP Switches on Front Panel

120 Ω Termination Resistor Switch	
Setting	Switch Position
ON - Ω	←
Ω - OFF	→

Connect Serial Ports

The RLH Serial Data Fiber Link transports two active channels of copper serial data over fiber optic cable, allowing for both RS-232 and RS-485/422 to be used at the same time. Serial connections are made to the screw down terminals, please refer to the terminal position diagram below.

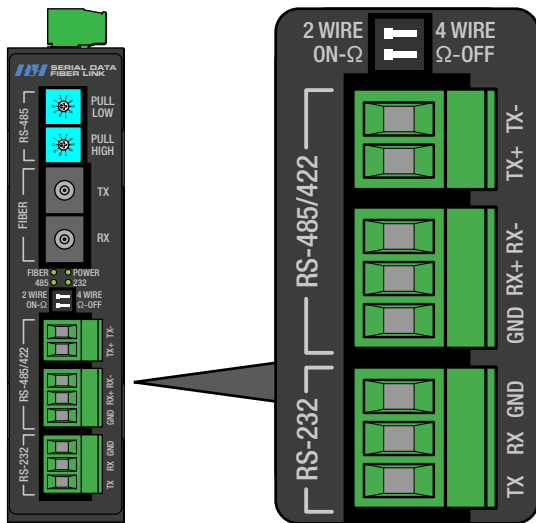

Detail of Serial Data Pluggable Terminals

RS-485 (2 Wire)	
Terminal	Function
TX- (DATA -)	RS-485/422 Transmit -
TX+ (DATA +)	RS-485/422 Transmit +
GND	Signal Ground

RS-485/422 (4 Wire)	
Terminal	Function
TX- (DATA -)	RS-485/422 Transmit -
TX+ (DATA +)	RS-485/422 Transmit +
RX-	RS-485/422 Receive -
RX+	RS-485/422 Receive +
GND	Signal Ground

RS-232	
Terminal	Function
GND	Signal Ground
RX	RS-232 Receive
TX	RS-232 Transmit

Connect Power

The system has redundant power terminals that accommodates a backup power supply in the event of an outage. Follow these steps when attaching wires to power terminals located on the top of the module.

- Check that DC power source voltage matches the accepted voltage range of the device to avoid damaging the unit.
- Disconnect power from the DC power source prior to connecting to the Fiber Link.
- Connect the DC power cables to the terminal pairs. The system is NOT polarity sensitive.
- Energize the power source. The POWER LED will be ON indicating that the system has power.

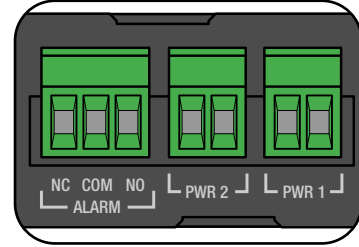

Detail of Power and Alarm Terminals

Connect Alarm Contact

Attach wiring from the equipment monitoring the Serial Data Fiber Link to the alarm terminals located on the top of the unit next to the power terminals. The alarm relay offers a Common, Normally Open, and Normally Closed position.

When the system is communicating and properly functioning the Fiber LED will light up and the alarm relay will energize. If DC Power is lost, Fiber is broken, or one side of the system stops functioning the alarm relay will de-energize.

Front Panel LED Indicators and Dip Switches

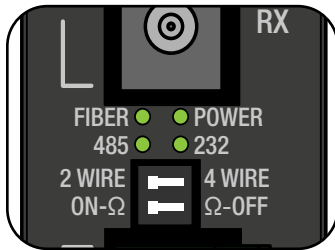

Detail of LED Indicators

Indicator	Color	LED	Description
FIBER	Green	Off	No Fiber Link detected
		On	Fiber Link detected
POWER	Green	Off	System has NO power
		On	System has power
485 (RS-485/422)	Green	On/Off	No activity
		Blinking	Copper signal received
232 (RS-232)	Green	On/Off	No activity
		Blinking	Copper signal received

Troubleshooting

The RLH Serial Data Fiber Link system is fully tested prior to shipping. If problems do occur, please follow the troubleshooting steps below prior to contacting support.

POWER LED Indicator OFF

- Check power supply voltage and rated device voltage.
- Check connections of the power terminals.

RS-232 and RS-485/422 LED Indicators Off

- Verify serial data pin-outs of each end device.
- Verify 2 wire / 4 wire dip switch is in the correct position.

FIBER LED Indicator Off

- Optic port connection is incorrect.
- Make sure fiber cable from the TX optic is connected to the RX optic on both ends of the system.
- Make sure single-mode equipment is using single-mode fiber and multimode equipment is using multimode fiber.

If all connections and indicators has been verified please contact the RLH support team for further assistance.

Ordering Information

Optics	Side	Distance	Wavelength	Fiber	Part Number
Dual Fiber Multimode SC	-	2 km/1.2 mi	1310nm	50/62.5 µm	SDD-03-3
Dual Fiber Multimode ST	-	2 km/1.2 mi	1310nm	50/62.5 µm	SDD-04-3
Single Fiber Single-mode SC	A	20km/12.4mi.	Tx 1310nm Rx 1550nm	8~9 µm	SDD-10-3
	B	20km/12.4mi.	Tx 1550nm Rx 1310nm	8~9 µm	SDD-11-3
	A	60km / 37mi.	Tx 1310nm Rx 1550nm	8~9 µm	SDD-14-3
	B	60km / 37mi.	Tx 1550nm Rx 1310nm	8~9 µm	SDD-15-3
Dual Fiber Single-mode SC	-	20km/12.4mi.	1310nm	8~9 µm	SDD-40-3
	-	60km / 37mi.	1310nm	8~9 µm	SDD-41-3
	-	120km / 74 mi.	1550nm	8~9 µm	SDD-45-3
Dual Fiber Single-mode ST	-	20km/12.4mi.	1310nm	8~9 µm	SDD-50-3
	-	60km / 37mi.	1310nm	8~9 µm	SDD-51-3
	-	120km / 74 mi.	1550nm	8~9 µm	SDD-55-3

- ▶ For the 125VDC input power option, please note the part number by adding **-A** to the end.
- ▶ For the 12VDC input power option, please note the part number by adding **-B** to the end.
- ▶ Bidirectional single fiber models require an **A** Side and **B** Side unit for a complete system.
- ▶ RLH SDD-XX-3 models are not backwards compatible with SDD-XX-2 models.
- ▶ Please contact your RLH sales representative for pricing and delivery information.

General Specifications

Transmission method	Frequency modulated light via two optical fibers		
	Multimode	1310nm	
	Single-mode	1310nm/1550nm	
Maximum Fiber Attenuation / Distance*	Single Fiber	Single-mode (8~9/125µm):	Up to 37 mi./60km range
	Dual Fiber	Multimode (50/62.5/125µm):	1.25mi./2 km range
		Single-mode (9/125µm):	Up to 74 mi./120km range
	<i>*Note: Distances equated using industry standard fiber and connector attenuation. Fiber condition, splices and connectors may affect actual range.</i>		
Connector Type	ST or SC Multimode or Single-mode		
Power Margin	11dB(2Km, M/M), 12dB ~ 35dB (20 ~ 120Km, S/M)		
Protocols	RS-232 and RS-485/422		
Latency	100ns		
Serial Signaling	RS-232	TX, RX, Ground	
	RS-485/422 (4 Wire)	TX-, TX+, RX-, RX+, Ground [DIP Switch - 4 Wire Function]	
	RS-485 (2 Wire)	TX+ (Data +), TX- (Data -), Ground [DIP Switch - 2 Wire Function]	
RS-485/422 Line Biasing	Use rotary dials for impedance adjustment. See <i>RS-485/422 Biasing</i> section for more information.		
Serial Connectors	Pluggable Terminal Block		
Signal Isolation	Optical Isolation 3.75 KV		
Baud Rates	50bps- 921.6kbps Automatic Detection		
DIP Switches	RS-485 (2/4 Wire)	Specifies 2 Wire RS-485 or 4 Wire RS-485/422 operation	
	Termination Resistor	ON position provides 120 ohm terminal resistance	
Supports	DNP / DFI / Modbus / Profibus		
LED	POWER	DC Power OK	
	FIBER	Fiber Connection OK	See <i>Front Panel LED Indicators</i> section in User Guide for more detailed information.
	232	RS-232 Copper Receive	
	485	RS-485/422 Copper Receive	
Power Input	24~VDC / 125VDC / 12VDC		
	Dual redundant power inputs		
Power Consumption	150mA @ 24VDC or 3.6 Watt		
DC Input Isolation (In/Out)	1.5KV		
Voltage Reversal Protection	Will operate with V+ or V- in either power terminal		
Over Current Protection	1.0A (Automatic Recovery)		
Temperature	Storage	-40°C to +85°C (-40°F to +185°F)	
	Operating	-40°C to +70°C (-40°F to +158°F)	
Dimensions/Mounting	H 4.93" x W 1.20" x D 3.93" (not including DIN clip)		
	Standard T-35 DIN rail mounting or wall mount with included brackets		
Warranty	Limited Lifetime		

Technical Support

Email:	support@fiberopticlink.com
24/7 technical support:	Toll Free 1-855-RLH-24X7 Toll Free 1-855-754-2497

Contact Information

Corporate Headquarters:	RLH Industries, Inc. 936 N. Main Street Orange, CA 92867 USA
Phone:	(714) 532-1672 Toll Free 1-800-877-1672 Toll Free 1-866-DO-FIBER
Fax:	(714) 532-1885
Email:	info@fiberopticlink.com
Web site:	www.fiberopticlink.com



RLH Industries, Inc.
936 N. Main Street, Orange, CA 92867 USA
T: (714) 532-1672
F: (714) 532-1885

Please contact your RLH sales representative for pricing and delivery information.

Specifications subject to change without notice.