



Industrial 200W Heater with Thermostat

RLH-H200-1

PTC Heating Technology, Touch-Safe Housing, Wall or DIN Rail Mounting

RLH Compact Fan Heaters are engineered to provide reliable temperature regulation and condensation prevention for industrial enclosures and control cabinets. Combining a high-efficiency 200W PTC heating element with an integrated fan and adjustable thermostat, these heaters maintain stable operating temperatures to help ensure the reliable performance and longevity of sensitive electronic equipment.

Designed for demanding industrial applications, RLH Compact Heaters feature a touch-safe, high-temperature plastic housing and a compact footprint that simplifies installation in space-constrained enclosures. Flexible mounting options allow for direct panel mounting or tool-free DIN rail installation using the included snap fastener, while UL-listed quick-connect terminals reduce installation time and simplify maintenance.

The self-regulating PTC heating technology provides safe and efficient operation by minimizing the risk of overheating, while the built-in adjustable thermostat allows the heater to be set to the desired temperature for the application. Ideal for industrial automation, communications, utility, and control panel environments, the RLH Compact Fan Heater helps protect sensitive equipment from condensation and temperature fluctuations.

Features

- Direct panel or tool-free DIN rail mounting with included snap fastener
- Touch-safe, high-temperature plastic housing
- Built-in adjustable thermostat for precise temperature control
- Includes AC power cord for simplified installation
- Compact design for space-constrained enclosures
- Integrated fan for efficient air circulation and heat distribution
- Self-regulating PTC heating element helps prevent overheating
- UL Recognized for easy integration into UL 508A panels



200W Heater on DIN Rail

Dimensions

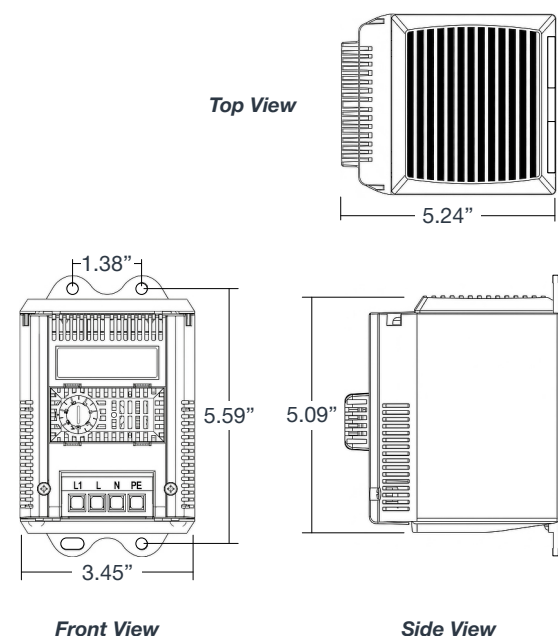



General Specifications

Heating Range	-4°F to +104°F (-20 to +40 °C)	
Heating Capacity	200W	
Power Consumption	215W	
Starting Current	9A	
Airflow Volume	30 CFM	50 (m3/h)
Dimensions	3.4 (W) x 5.2 (L) x 5.6 (H) (88mm x 133 x 142)	
Construction	Thermally Resistant Plastic (IP20 Rated)	
Mounting	Wall or DIN Rail Mountable (Includes DIN Rail Clip)	
Operating Temperature	-40°C to +70°C (-40°F to +158°F)	
Humidity	90% Non Condensing	
Compliance	CE, UL Listed	

Ordering Information

Description	Part Number
200 Watt Compact Heater, DIN/Wall Mountable, 115VAC	RLH-H200-1

Contact

By Mail:	ATTN: Sales RLH Industries, Inc. 936 N. Main Street Orange, CA 92867	
By Phone:	Local	714-532-1672
Sales/Service	Toll Free	800-877-1672
By Email:	info@fiber optic link.com	
By Fax:	714-532-1885	

Support

By Email:	support@fiber optic link.com
By Phone:	Toll Free 855-754-2497