



# 4 Channel 4~20mA Fiber Converter with SFP

FBX-420-INPUT-1 / FBX-420-OUTPUT-1

Transmit Four 4~20mA Analog Signals Over Fiber with High Speed and Accuracy

## Introduction

The RLH 4~20mA Fiber Optic Converter transmits 4 Analog signals over fiber cable and offers high performance with 30kHz bandwidth, 16 bit signal resolution, and less than 0.2% source signal variance.

It is compatible with most PLC's, Sensors (2, 3, or 4 wire), and other types of equipment where a precise current measurement must be taken and transmitted over fiber. The system comprises of a transmitter (Analog Input) and a receiver (Analog Output).

This compact and rugged system provides convenient and easy to read LEDs, supports both singlemode and multimode fiber applications, and includes an alarm contact for monitoring system power and fiber health.

This system is engineered to operate over an extreme temperature range, providing reliability in harsh environments. It is designed, engineered, and assembled in the USA, and covered by our Lifetime Warranty.



4 Channel 4~20mA Input Fiber Converter shown with SFP Transceiver Installed

## Features

Compatible with all MSA compliant Gigabit SFPs

30kHz bandwidth

16 Bit Signal Resolution

99.8% Accuracy or Better Guaranteed

Alarm contact for system status monitoring

Hardened to operate in -40°F to +158°F (-40°C to +70°C)

DIN rail or Wall Mount (Wall mount ears included)

Redundant Power Inputs (12~48VDC)

Designed, Engineered, and Assembled in the USA

Lifetime Warranty



## General Safety Practices

### Intended Audience

This guide is intended for use by knowledgeable installation, operation and repair personnel. Every effort has been made to ensure the accuracy of the information in this guide. However, due to constant product improvement, specifications and information contained in this document are subject to change without notice.

### Conventions

Symbols for notes, attention, and caution are used throughout this manual to provide readers with additional information, advice when special attention is needed, and caution to prevent injury or equipment damage.

The equipment discussed in this document may require tools designed for the purpose being described. RLH recommends that service personnel be familiar with the correct handling and use of any installation equipment used, and follow all safety precautions including the use of protective personal equipment as required.

### Caution - Severe Shock Hazard

- Never install during a lightning storm or where unsafe high voltages are present.
- Active phone lines may carry high DC voltages. Use caution when handling copper wiring.
- Do not open the enclosure, there are no user serviceable parts.

### Guidelines for handling terminated fiber cable

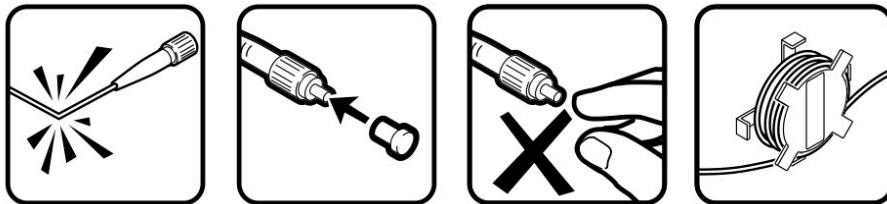

- Do not bend fiber cable sharply. Use gradual and smooth bends to avoid damaging glass fiber.
- Keep dust caps on fiber optic connectors at all times when disconnected.
- Do not remove dust caps from unused fiber.
- Keep fiber ends and fiber connectors clean and free from dust, dirt and debris. Contamination will cause signal loss.
- Do not touch fiber ends.
- Store excess fiber on fiber spools at site

### Laser Safety



Do not look directly into a fiber-optic transceiver or into the ends of fiber-optic cables.

Fiber-optic transceivers and fiber-optic cable connected to a transceiver emit laser light that can cause eye damage.

## System Description

### Applications

By utilizing fiber optic cable, the 4~20mA system provides absolute electrical isolation between both ends of the control system. It provides immunity to EMI/RF interference, ground loops, and high voltage surges from lightning or ground faults, and is ideal in electrically noisy environments such as near large power sources, electrical motors, and radio communications equipment. Fiber optic cable also allows for a signal transmission of up to 120km over fiber optic cable from the source signals location.

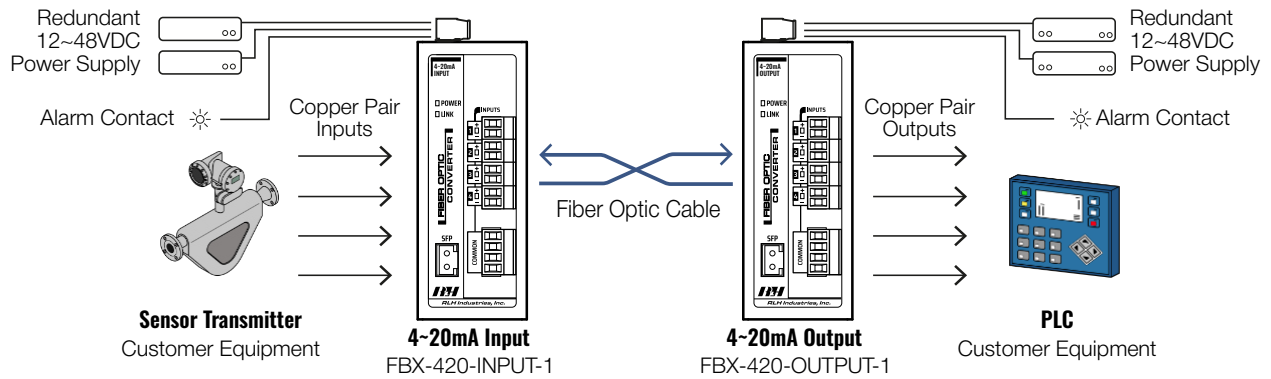

**System Diagram**

### Commonly Used Acronyms & Abbreviations

Name	Description
<b>TX</b>	Transmit
<b>RX</b>	Receive
<b>PWR</b>	Power
<b>NC</b>	Normally Closed
<b>Com</b>	Common
<b>NO</b>	Normally Open
<b>TRX</b>	4~20mA Transmitter
<b>RCV</b>	4~20mA Input/Receiver
<b>Sinking</b>	Does not provide signal voltage or current, expects the voltage and current to be present on the signal line
<b>Sourcing</b>	Provides signal voltage and current

## System Description

### 4~20mA System – 2-Wire Transmitter Wiring

Connecting a 2-Wire Transmitter to the RLH Fiber Transmitter (FBX-420-XX-1). The RLH Transmitter is always a sinking input, expecting the source current to be supplied by the remote device. In this example, the 2-Wire Transmitter has 24VDC loop voltage provided by a separate power supply. Below is a typical configuration for loop powered sensors (Flow, pressure, temperature, etc.).

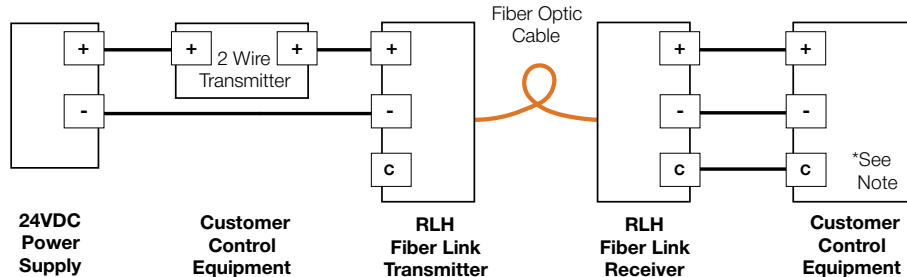

**Note:** Use common terminal when connecting RLH receiver to differential inputs

### 4~20mA System – 3-Wire Transmitter Wiring

Connecting a 3-Wire Transmitter to a RLH Transmitter (FBX-420-XX-1). The RLH Transmitter is always a sinking input, expecting the source current to be supplied by the remote device. The common terminal can be used from the transmitter, and if used it should connect to the negative terminal of the Fiber transmitter and the negative terminal of the power supply. Below is a typical configuration for 3-Wire Transmitters.

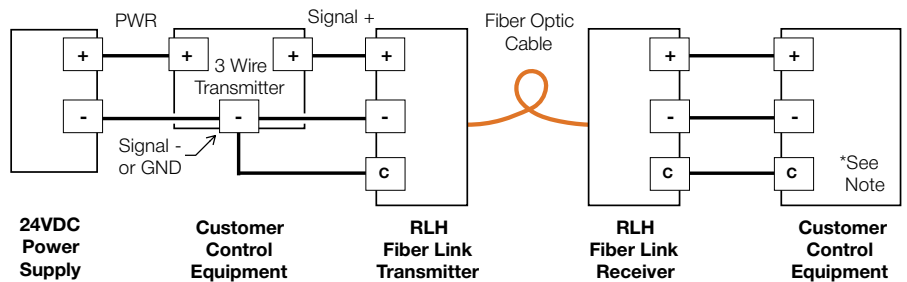

**Note:** Use common terminal when connecting RLH receiver to differential inputs

### 4~20mA System – 4-Wire Transmitter Wiring

Connecting a 4-Wire Transmitter to a RLH Transmitter (FBX-420-XX-1). The RLH Transmitter is always a sinking input, expecting the source current to be supplied by the remote device. Below is a typical configuration for a 4-Wire Transmitter.

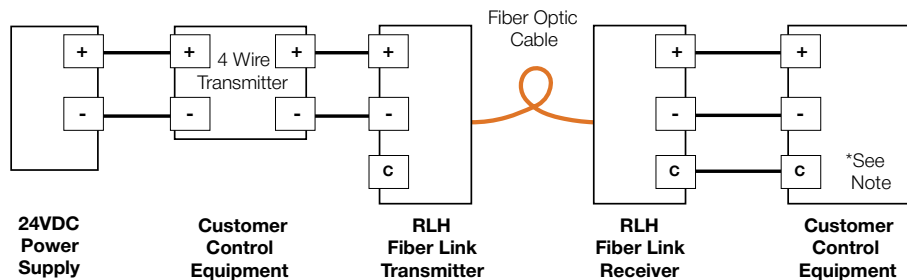

**Note:** Use common terminal when connecting RLH receiver to differential inputs

### Fiber Ring Mode

The RLH 4 Channel 4~20mA Fiber Optic Converter with SFP's Fiber Ring Mode is a networking topology where multiple converter modules are interconnected in a loop, or ring, of simplex fiber connections between adjacent units. This is achieved automatically by daisy-chaining the optical transmit (TX) and receive (RX) ports between each upstream and downstream module's SFP transceiver.

In Fiber Ring Mode, up to four independent 4~20mA signals are distributed across the Fiber Ring from one Input module (FBX-420-INPUT-1) to multiple Output modules (FBX-420-OUTPUT-1). This system architecture ensures the accurate reproduction of each 4~20mA signal input, guaranteeing less than 0.2% source signal variance, even when transmitted over long distances. The overall system latency between the Input module, and final downstream Output module, increases by 1µs for each additional Output module contained in the Fiber Ring.

Incorporating a Fiber Ring topology provides an easily scalable, modular form of incremental growth for industrial 4~20mA networks, by minimizing the amount of fiber and converter modules required to connect multiple remote sites. This arrangement also simplifies the troubleshooting of signal transmission failures by isolating the individual fiber links in which the 4~20mA signal flow is interrupted.

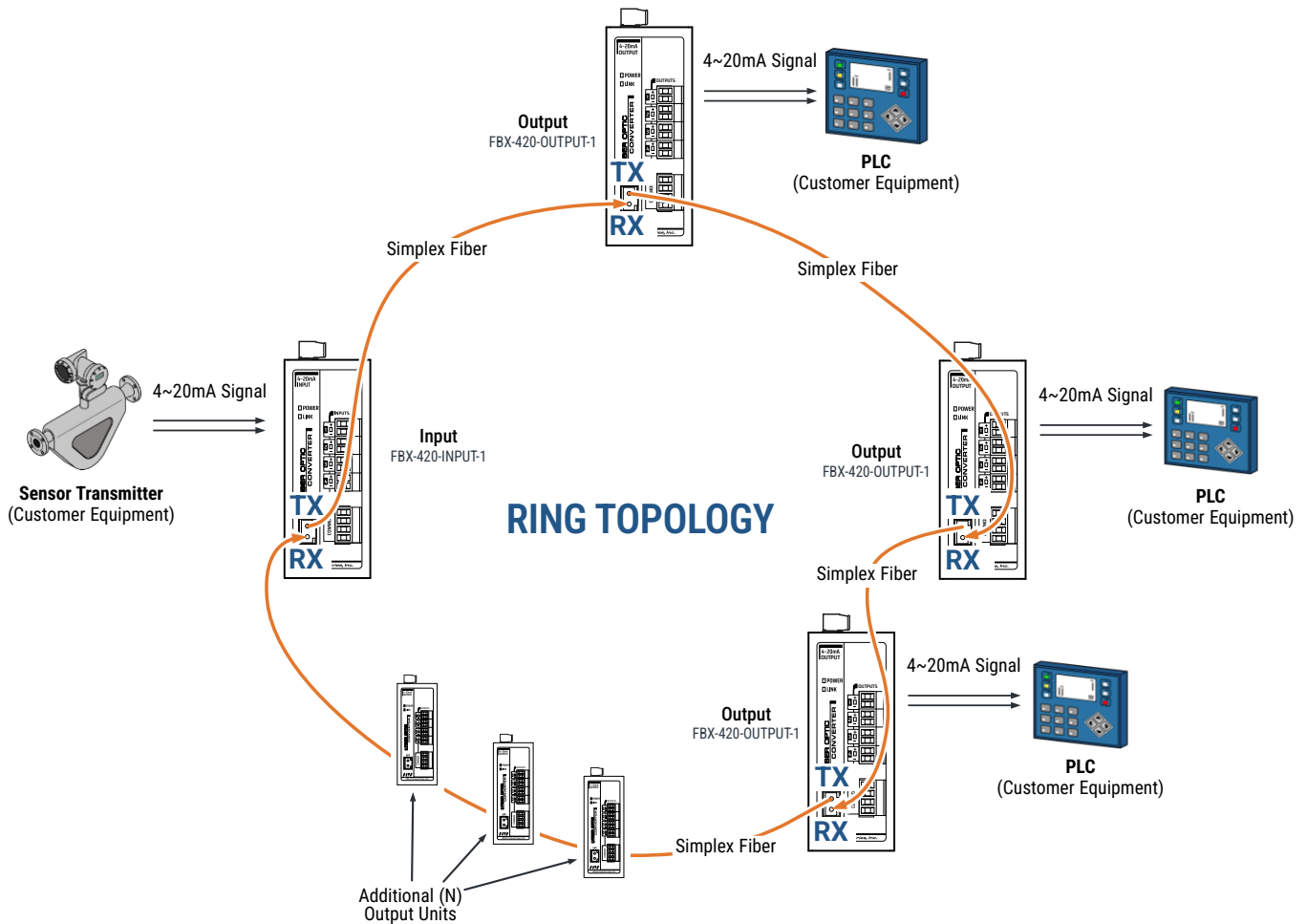

## Installation

### Prior to Installation

Check for shipping damage:

- Check the contents to ensure correct model and fiber type
- Have a clean, dry, installation environment ready

### Required for installation:

- 12-48 VDC Power Source
- T35 DIN rail or suitable wall mount location
- A weatherproof enclosure is required for outdoor use

### Front Panel

The front panel contains the input or output contact terminals, LED's, and the SFP Transceiver fiber port.

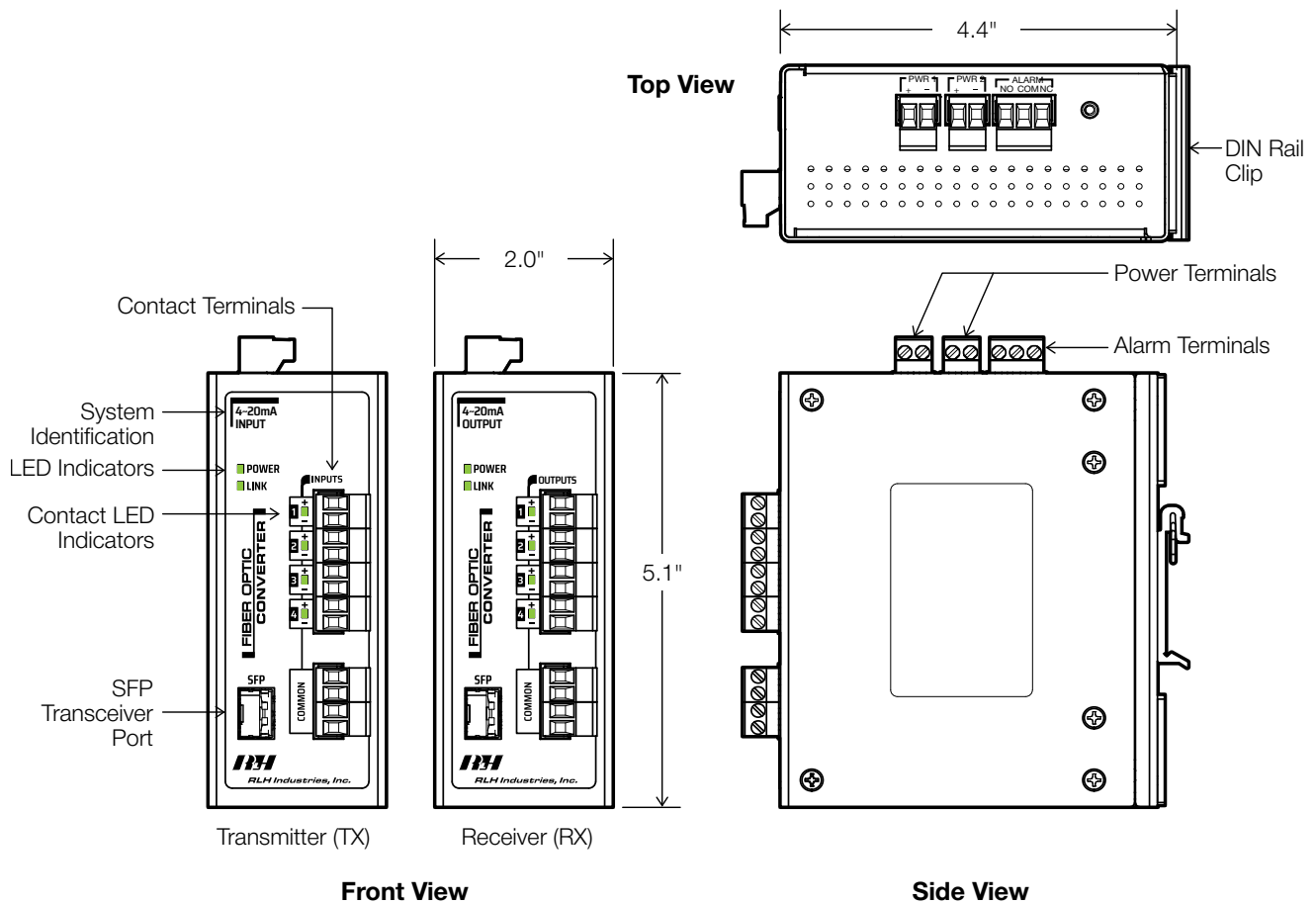

### DIN Rail Mounting

The DIN clip for mounting the system is mounted onto the rear panel. Hook the DIN clip on the top flange of the DIN rail, press down and rotate to the locked position to install. To remove, push down to depress the spring latch and rotate off of the DIN rail.

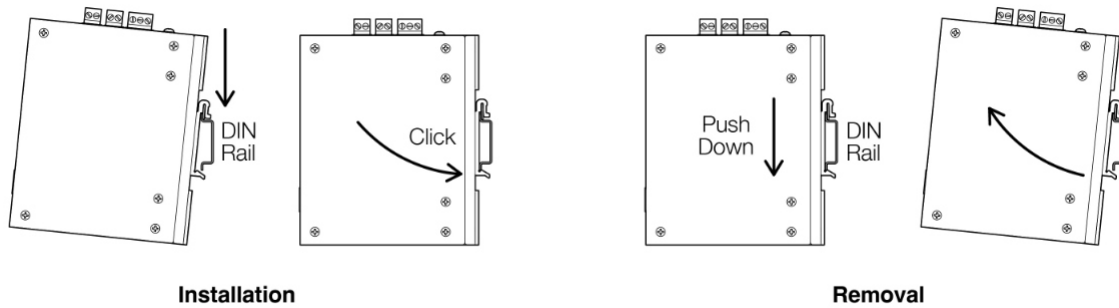

*DIN Rail Mounting*

### Wall Mounting

The system can be easily wall mounted by attaching the provided wall mount ears and hardware. Attach the wall mount ears by following the instructions below.

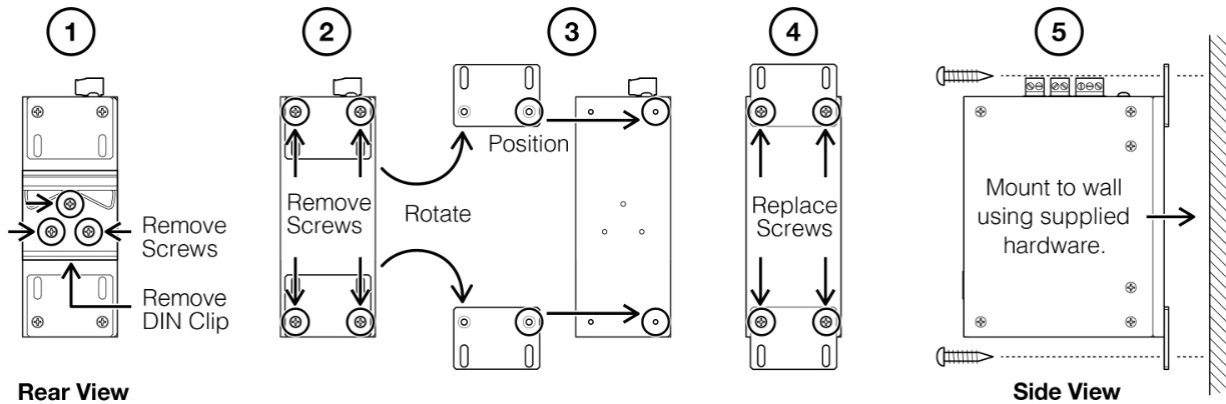

*Wall Mounting*

### Front Panel LEDs

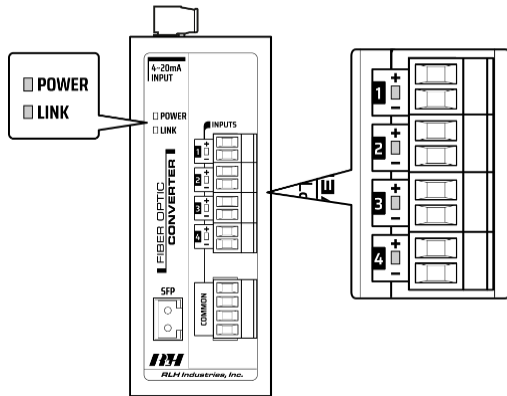

LED	Name	Status	Condition
Power	Power Indicator	ON	DC input power OK
		OFF	DC Input power failed
Link	System Link	Blinking	Fiber Link OK
		OFF	Fiber Link Failed
Input	4~20mA Input	ON	Signal Present
		OFF	No Signal Present
		Blinking	Signal Over Range
Output	4~20mA Output	ON	Signal Present
		OFF	No Signal Present
		Blinking	Signal Over Range

### SFP Transceiver

This system requires MSA compliant, Gigabit fiber optic SFP transceivers. An Industrial grade SFP is recommended to enable reliable operation throughout the entire operational range. SFP transceivers are sold separately.

- Dual fiber systems require identical SFP transceivers.
- Single fiber systems require a matching pair, side A and side B.
- Close clasp and slide the SFP transceiver into the port.
- To remove, pull the clasp back to release it, and then slide it out

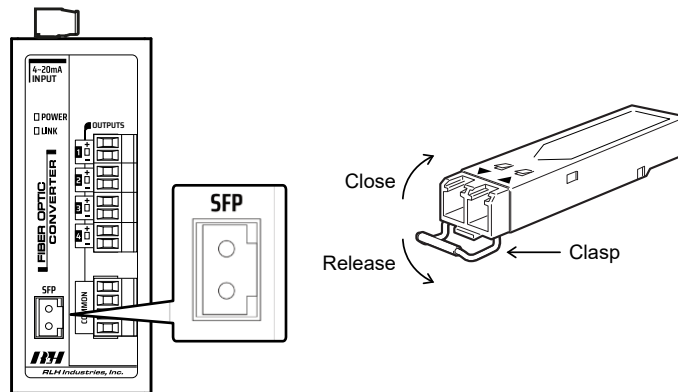

**SFP Transceiver**

### Connect Fiber Optic Cable

The optical ports are for use with SFP transceivers only. Remove the dust caps from the SFP transceiver and fiber connectors. Plug the cable(s) securely into the SFP.

- Dual fiber systems require the fiber port to be connected to the fiber port on the other end.
- Once the system is properly connected and power is applied, the LINK LED will BLINK while the link is active.

### Connect Copper Wire Pairs

The wire pairs from the sensor or controller equipment connect to the green screw-down terminals on the transmitter and receiver modules labeled Input and Output.

- Observe polarity on the Input and Output connectors.
- The contact terminals may be removed and accept wire sizes 16~26 AWG, rated at 105°C minimum.
- Fully seat the terminal block back into the connector before operating the system.
- When using 3-Wire devices, ensure common terminals are connected.

### Receiver Alarm Contact Wiring

The contact will alarm when the fiber link is down or due to a power failure.

- Use the NO or NC contact positions as required.
- The contact terminals may be removed and accept wire sizes 16~26 AWG, rated at 105°C minimum.
- Fully seat the terminal block back into the connector before operating the system.
- An alarm terminal is present on both the Transmitter and Receiver.

### Connect Power Cable

Ensure power supply is OFF prior to wiring the system. Connect a 12-48VDC power supply to the screw down terminals located on the top of the unit.

- Requires one (1) 12-48VDC power supply. Use a second power source for redundant power.
- The contact terminals may be removed and accept wire sizes 16~26 AWG, rated at 105°C minimum.
- Fully seat the terminal blocks back into the connector before operating the system.

**Note:** The power inputs are polarity insensitive. Be sure to verify the appropriate power source is being used before wiring.

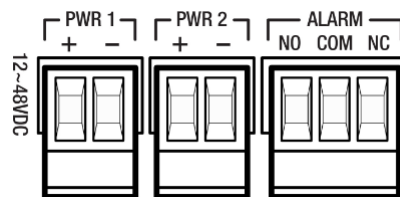

**Power and Alarm Terminals**

## Troubleshooting

Ensure power supply is OFF prior to wiring the system. Connect a 12-48VDC power supply to the screw down terminals located on the top of the unit.

- Requires one (1) 12-48VDC power supply. Use a second power source for redundant power.
- The terminal blocks are removable and accept wire sizes 16~26 AWG.
- Fully seat the terminal blocks back into the connector before operating the system.

If trouble is encountered, verify all copper, serial cable and fiber connections, signal and voltage levels, if the alarm is on, check the fiber cable and connections, or the power supply and connections of the unit on the other end. If trouble persists, contact technical support at RLH Industries, Inc.

[support@fiberoptick.com](mailto:support@fiberoptick.com)  
Toll Free: 1-855-754-2497

### Analog Inputs 1~4 (differential inputs)

<b>Operating Range</b>	0~20mA (DC) using separate 24VDC power supply
<b>Impedance</b>	250 Ohms
<b>Protection</b>	24mA

### Analog Outputs 1-4 (single-ended, unipolar)

<b>Loop Voltage</b>	23.7VDC
<b>Maximum Loop Resistance</b>	1000 Ohms
<b>Maximum Output Signal</b>	20mA each

### General Specifications

<b>Accuracy</b>	99.8% or Better Guaranteed Note: Accuracy for Fiber Link System, both Transmitter and Receiver at 25°C and powered by 24VDC	
<b>Ambient Temp Effect</b>	Approximately 0.4% over range -40°F to +158°	
<b>Bandwidth</b>	30kHz	
<b>Latency</b>	1µs	
<b>Signal Resolution</b>	16 Bits	
<b>Sensitivity</b>	2 <sup>16</sup> (65,536) Steps	
<b>SFP Transceiver Port</b>	1 Gigabit SFP Slot, Accepts MSA compliant 1.25Gbps SFPs (Transceiver not included with the product, Class 1 laser source)	
<b>LED Indicators</b>	Power, Fiber, Input/Outputs 1~4 12~48VDC (11~53V)	
<b>Power Input</b>	-A powering option 125VDC (42~160V) Dual redundant power options - Polarity insensitive	
<b>Power Consumption</b>	Input Device	1A, 6 Watts Maximum
	Output Device	1A, 8 Watts Maximum
<b>DC Input Isolation (In/Out)</b>	1.5KV	
<b>Overcurrent Protection</b>	1.0A	Automatic Recovery
<b>System Alarm</b>	Normally Open / Closed Relay	
<b>Alarm Relay</b>	30VAC, 0.5A or 60VDC, 0.3A, resistive load	
<b>Temperature</b>	Storage	-40°C to +85°C (-40°F to +185°F)
	Operating	-40°C to +70°C (-40°F to +158°F)      UL Approved: -40°C to + 43°C (-40°F to +109°F)
<b>Dimensions</b>	2.0" (W) x 4.3" (D) x 5.1" (H),    (51mm x 109mm x 130mm) - not including DIN clip	
<b>Mounting</b>	Dry location, open type. Includes standard T-35 DIN rail clip and wall mount ears	
<b>Humidity</b>	95% non-condensing	
<b>Safety</b>	NDAA, TAA, FCC Class A, UL, CE, RoHS, Reach	
<b>MTBF (MIL-HDBK-217F2, GB, 25°C)</b>	FBX-420-INPUT-1	153,402 hours - (MIL-HDBK-217F2, GB, 25°C)
	FBX-420-OUTPUT-1	150,772 hours - (MIL-HDBK-217F2, GB, 25°C)
<b>Warranty</b>	Lifetime - Visit <a href="http://www.fiberopticlinc.com">www.fiberopticlinc.com</a> for warranty information and coverage details	

- Certified for indoor location. Open style device must be installed in suitable enclosure for protection.
- Use in a manner not specified may impair protection provided by equipment.



## Ordering Information

Description	Part Number
4~20mA Fiber Optic Converter, Input, 4 Channels, 1 SFP Slot, powered by 12~48VDC	<b>FBX-420-INPUT-1</b>
4~20mA Fiber Optic Converter, Output, 4 Channels, 1 SFP Slot, powered by 12~48VDC	<b>FBX-420-OUTPUT-1</b>

- A complete system requires one **INPUT** and one **OUTPUT** unit.
- Add **-A** to the end of the part number for 125VDC powering option.
- Single fiber (bi-directional) SFP transceivers must always be paired, side A and side B.

## RLH Certified SFP Transceivers

Description	Mode	Conn.	Distance	Fibers	Wavelength	Part Number
Multimode, LC, 550m/1804 feet, Dual Fiber, 850nm	MM	LC	550m/1804 feet	Dual Fiber	850nm	<b>SFP-1G-03-2</b>
Multimode, LC, 2km/1.2 miles, Dual Fiber, 1310nm	MM	LC	2km/1.2 miles	Dual Fiber	1310nm	<b>SFP-1G-04-2</b>
Singlemode, LC, 20km/12.4 miles, Dual Fiber, 1310nm	SM	LC	20km/12.4 miles	Dual Fiber	1310nm	<b>SFP-1G-30-2</b>
Singlemode, LC, 60km/37 miles, Dual Fiber, 1550nm	SM	LC	60km/37 miles	Dual Fiber	1550nm	<b>SFP-1G-31-2</b>
Singlemode, LC, 120km/74 miles, Dual Fiber, 1550nm	SM	LC	120km/74 miles	Dual Fiber	1550nm	<b>SFP-1G-34-2</b>
Singlemode, LC, 20km/12.4 miles, Single Fiber – Side A, Tx1310/Rx1550	SM	LC	20km/12.4 miles	Single Fiber Side A	T-1310/ R-1550	<b>SFP-1G-20-2</b>
Singlemode, LC, 20km/12.4 miles, Single Fiber – Side B, Rx1310/Tx1550	SM	LC	20km/12.4 miles	Single Fiber Side B	T-1550/ R-1310	<b>SFP-1G-21-2</b>
Singlemode, LC, 60km/37 miles, Single Fiber – Side A, Tx1310/Rx1550	SM	LC	60km/37 miles	Single Fiber Side A	T-1310/ R-1550	<b>SFP-1G-24-2</b>
Singlemode, LC, 60km/37 miles, Single Fiber – Side B, Rx1310/Tx1550	SM	LC	60km/37 miles	Single Fiber Side B	T-1550/ R-1310	<b>SFP-1G-25-2</b>

- Single fiber (bi-directional) SFP transceivers must always be paired, side A and side B

## Contact

<b>By Mail:</b>	AN: Sales	
	RLH Industries, Inc. 936 N. Main Street Orange, CA 92867	
<b>By Phone:</b>	Local	714-532-1672
<b>Sales/Service</b>	Toll Free	800-877-1672
<b>Mon - Fri, 6am - 6pm, PST</b>		866-DO-FIBER
<b>By Email:</b>	info@fiberoptick.com	
<b>By Fax:</b>	714-532-1885	

## Support

<b>By Email:</b>	support@fiberoptick.com	
<b>By Phone:</b>	Toll Free	855-754-2497
		855-RLH-24X7