

2 Channel POTS DIN Fiber Link System

SYSTEM INSTALLATION INFORMATION

The RLH 2 Channel Plain Old Telephone Service (POTS) DIN Fiber Link system transports two analog phone lines over fiber optic cable. The system will operate over a wide temperature range and has been designed to provide reliability in harsh environments.

Common applications include extending analog lines over fiber for the benefit of electrical isolation, to achieve long distances, or through noisy environments to reduce EMI. The system is compatible with all traditional analog phone services, dial-up modems, meters, and fax machines.

A comprehensive set of LED's on the front panel indicate the status of the power, fiber, and phone lines. The standard system powering requirement is 24-48VDC, with an optional 125VDC available. This rugged system also features dual redundant power inputs with a system alarm contact relay, and comes standard with DIN clip and wall mount ears. RLH Fiber Link systems are designed and Made in the USA, and are covered by our Lifetime warranty.

Key Features

- Wide operating temperature range
-40°F to +158°F (-40°C to +70°C)
- Extends telephone up to 74 miles miles (120km)
- Multimode or single-mode fiber, and SC or ST connectors
- Single and dual fiber models available
- Supports Caller ID
- Supports Call-Forward Disconnect (Hook Flash)
- Ringdown Function (FXS to FXS Hotline Phone)
- Convenient LED status indicators
- Compatible with standard 2 wire analog phone lines, dial-up modems, and fax machines
- **Made in the USA** covered by our **Lifetime Warranty**



2 Channel POTS DIN Fiber Link System

Contents

Introduction	1
General Safety Practices	2
Special Handling Requirements	2
Acronyms	3
Applications	3
Installation	5
Operation	8
Status and Activity LED's	8
Specifications	9
Ordering Information	10

General Safety Practices

Intended Audience

This guide is intended for use by knowledgeable telco/network installation, operation and repair personnel. Every effort has been made to ensure the accuracy of the information in this guide is accurate. However, due to constant product improvement, specifications and information contained in this document are subject to change without notice.

Conventions

Symbols for notes, attention, and caution are used throughout this manual to provide readers with additional information, advice when special attention is needed, and caution to prevent injury or equipment damage.

The equipment discussed in this document may require tools designed for the purpose being described. RLH recommends that service personnel be familiar with the correct handling and use of any installation equipment used, and follow all safety precautions including the use of protective personal equipment as required.

Caution - Severe Shock Hazard

- Never install during a lightning storm or where unsafe high voltages are present.
- Active phone lines may carry high DC voltages. Use caution when handling copper wiring.
- The DIN chassis must be grounded using the ground screw to reduce the risk of damage from lightning.

Guidelines for handling terminated fiber cable

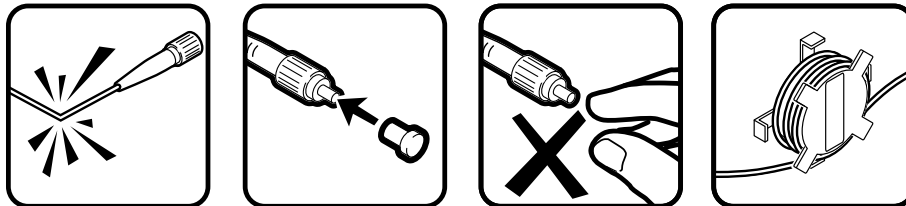

- Do not bend fiber cable sharply. Use gradual and smooth bends to avoid damaging glass fiber.
- Keep dust caps on fiber optic connectors at all times when disconnected.
- Do not remove dust caps from unused fiber connectors.
- Keep fiber ends and fiber connectors clean and free from dust, dirt and debris. Contamination will cause signal loss.
- Do not touch fiber ends.
- Store excess fiber on housing spools or fiber spools at site

Acronyms

Commonly used acronyms and abbreviations

Acronym/Abbreviation	Description
POTS	Plain Old Telephone Service (analog phone)
FXO	Foreign Exchange Office or Central Office location
FXS	Foreign Exchange Station or Subscriber side location
PBX	Private Branch Exchange
TX	Transmit
RX	Receive
MM	Multimode
SM	Single Mode
2W	Refers to 2 wire copper analog phone line
LED	Light Emitting Diode

Applications

Optical fiber is immune to EMI/RF interference, ground loops, and high voltage surges from lightning or ground faults, and is ideal for electrically noisy environments such as near large power sources, electrical motors, and radio communications equipment. Using fiber optic cable provides long distance service (up to 120km/74mi.) without any additional equipment.

Safety benefits of fiber optics

Placement of all-dielectric fiber optic cable (instead of copper) completely eliminates the presence of a remote ground, which dramatically increases safety of personnel and reliability of equipment. By using fiber optic cable, the 2 Channel POTS system provides absolute electrical isolation.

FXO Fiber Link device

The FXO Fiber Link device provides the electrical to optical interface between any inbound telephone lines, for example a PSTN phone line delivered from a service provider or a analog PBX phone line.

FXS Fiber Link device

The FXS Fiber Link device provides the optical to electrical interface in the system. The devices are meant to interface with end devices such as telephones, modems, or fax machines.

Caller-ID (CLID)

RLH FXO & FXS Fiber Link devices are designed to fully support Caller ID Pass-through. The system supports both Single Data Message Format (SDMF) & Multiple Data Message Format (MDMF). If present both the Calling Party Name and Calling Party Number will be transmitted via Fiber to the remote party.

Call Forward-Disconnect

Also known as disconnect supervision our systems will transmit battery drops to the FXO interface letting the remote party know that the phone has been hung up. Also by having this feature we're able to support Hook Flash (Flashing) on traditional telephones.

This Call-Forward disconnect feature is one that is not common to all POTS fiber extension devices and we're glad to offer this as a standard feature in our product. It is especially important to have when integrating our system with a PBX or Modem as without it those devices may not properly return on-hook after a call has been completed.

Application Diagrams

The diagrams below show the two different configurations of the POTS system. Refer to the [Ordering Information](#) and [Specifications](#) sections for additional information.

FXO to FXS - Phone Line Extension

When a link is created between FXO & FXS Fiber Link devices the system will act as a phone extender. The inbound phone line will be connected to the FXO device and transmitted over Fiber to the FXS device, where the signal will be regenerated back into copper transparently as shown in the diagram below.

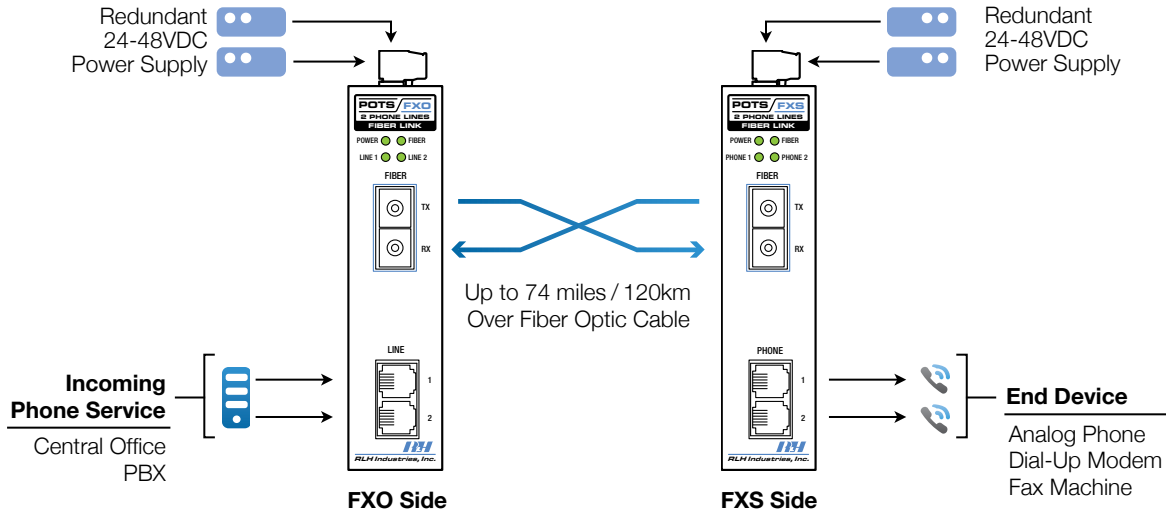

FXS to FXS - Ringdown (Hotline Phone)

When a link is created between two (2) FXS Fiber Link devices a standard telephone can be connected to each side and when either of the phones are taken off-hook the other end will ring until answered. Once answered an audio session will be established until either end hangs up. This type of configuration creates a closed circuit point to point telephone system.

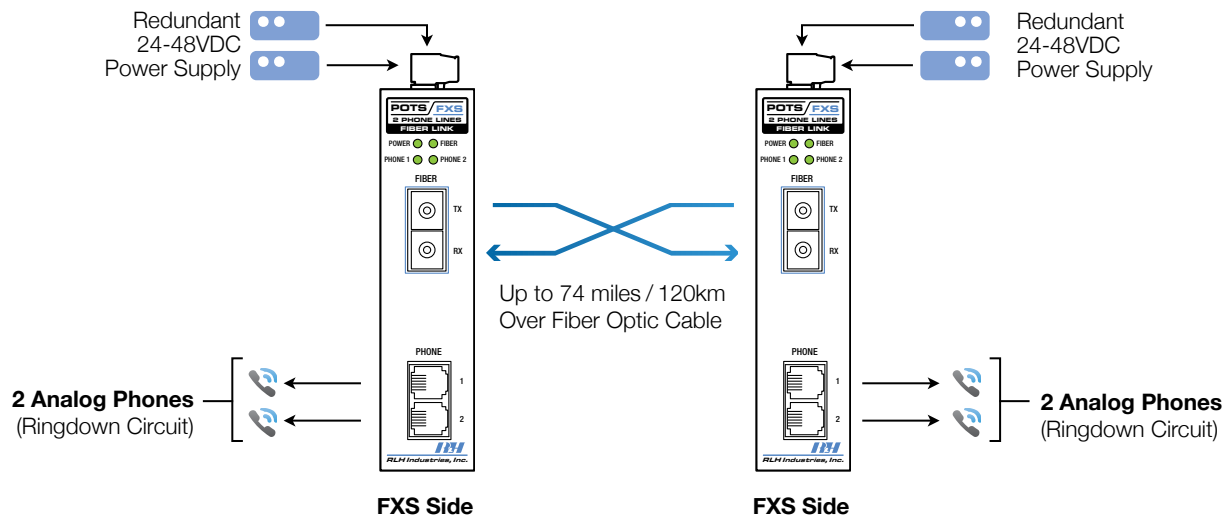

Installation

Prior to installation

- Check for shipping damage
- Check the contents to ensure correct model and powering options
- Make sure you have the correct fiber type and power available
- Have a clean, dry installation environment ready

Required for installation:

- Suitable wall, panel, or DIN rail space.
- Local power source (24~48VDC or 125VDC depending on model).
- Flat head screwdriver for connection wiring.
- Phillips screwdriver for attaching to wall (optional).

Physical layout

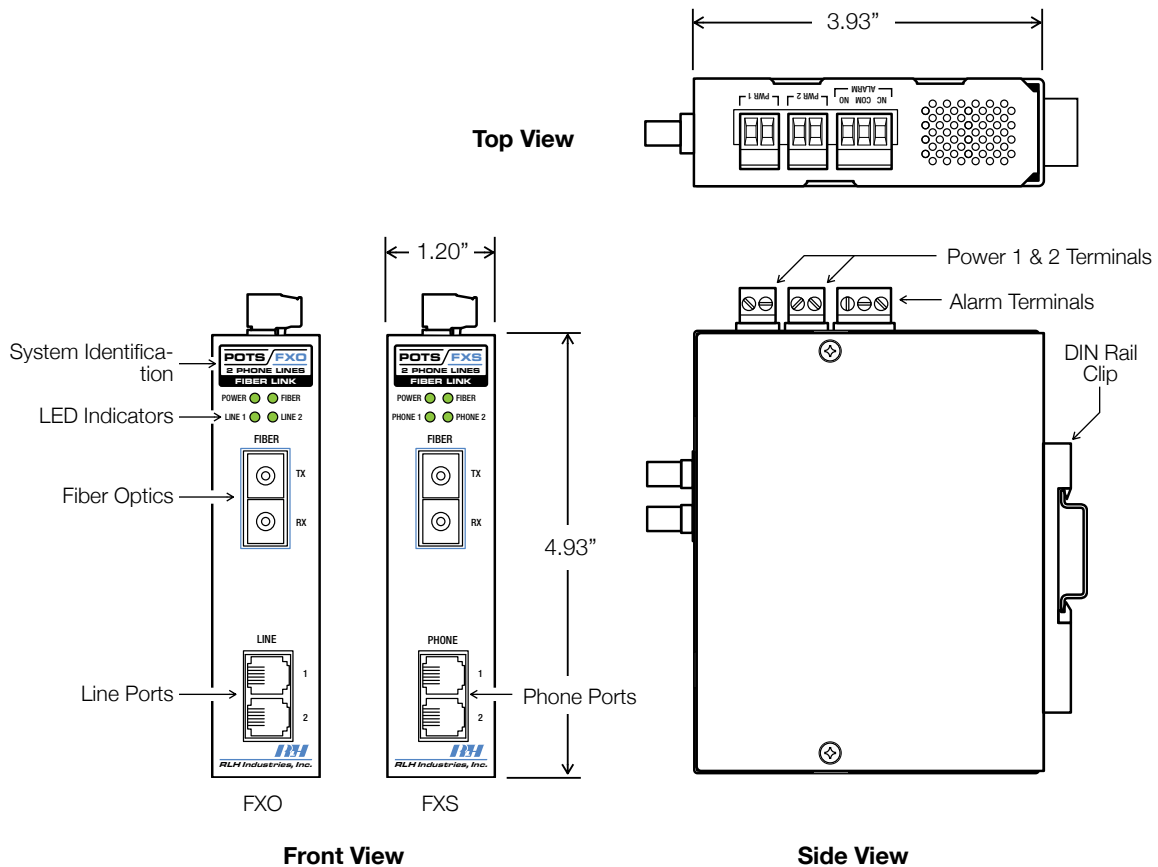

DIN rail mounting

The DIN clip for mounting the system is mounted onto the rear panel. Hook the DIN clip on the top flange of the DIN rail and rotate to the locked position to install. To remove, push up to depress the spring latch and rotate off of the DIN rail.

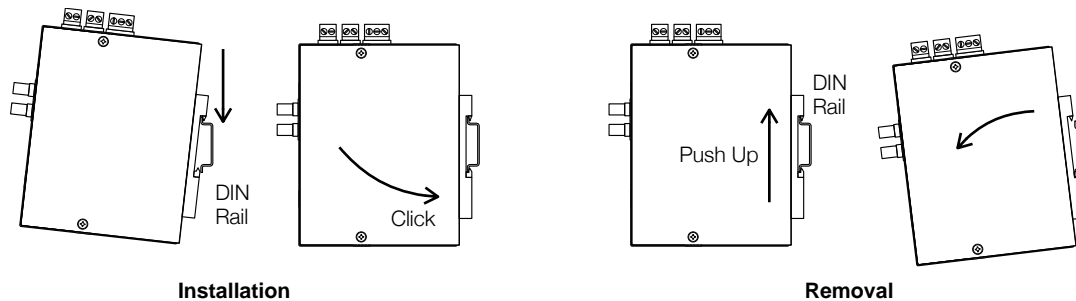

DIN Rail Mounting

Wall mounting

The system can be easily wall mounted by attaching the provided wall mount ears and hardware. Attach the wall mount ears by following the instructions below.

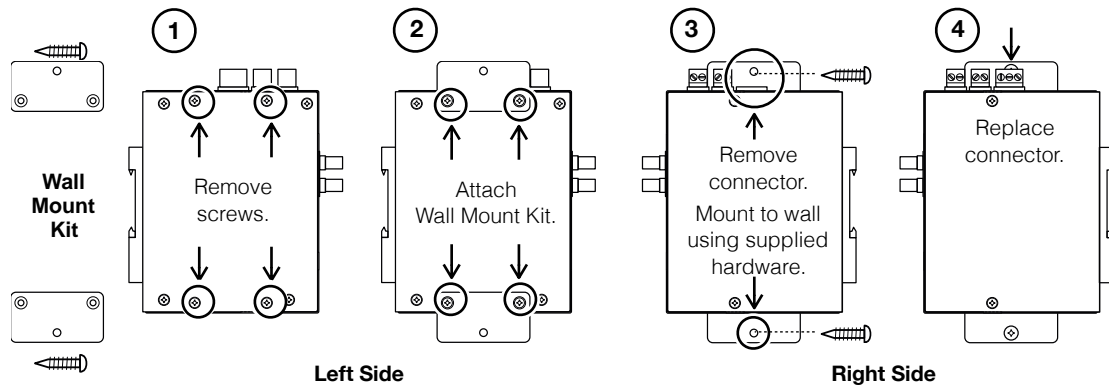

Wall Mounting

Connect optical fiber cable

The optical ports may be equipped with ST or SC fiber connectors. A fiber pair is required for operation with dual fiber models, TX is the output signal and RX is the input signal. Single fiber models combine input and output signals over one fiber strand.

Connect fiber cables to the correct TX and RX ports. On dual fiber models, the TX port of one side must be connected to the RX port of the unit at the other side. Make sure the connections are made accordingly at both ends of the Fiber Link.

Do not remove fiber cable caps until you connect the fiber to the unit. Exposing the mating optical interface to the surrounding environment should be limited to installation & maintenance only.

Connect analog phones

Each 2 Channel POTS Fiber Link device has two RJ-11 female connectors, one for each of the line/phone ports. The line/phone uses the center two pins of the RJ-11 connector. The RJ-11 male connector pinouts are indicated in the diagrams and table below.

RJ-11 Pinout Table

	POTS Line/Phone	RJ-11 Female (On Device)	6 Pin RJ-11 Male	4 Pin RJ-11 Male
1 ~ 2	Ring	3	3	2
	Tip	4	4	3

6 Pin RJ-11 male to 6 Pin RJ-11 Female

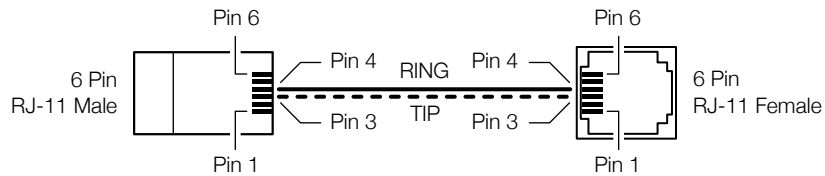

4 Pin RJ-11 male to 6 Pin RJ-11 Female

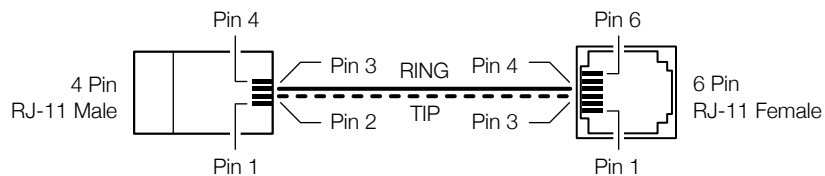

Connect Power

The POTS system accepts a 24-48VDC or 125VDC local power source depending on the model. The power inputs are identified on the top of the device, near the alarm terminals and are labeled PWR 1 and PWR 2. Either or all of them may be used to power the device.

Connect the leads of the power source to the screw down terminals on top of the DIN device. For ease of installation, the terminal block may be removed by pulling it straight out. If removed, seat the terminal block firmly into the connector before applying power. Once power is applied the power LED will turn on.

Note: The power terminals are not polarity sensitive. The positive or negative lead of the power source may be connected to either terminal of the power connectors.

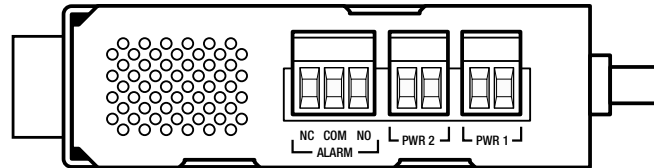

Detail of Power Terminals

Operation

The 2 Channel POTS system has four (4) green LED status indicators on the front panel of the device. Below is a table for a description of the LED indicators.

Status and Activity LED display

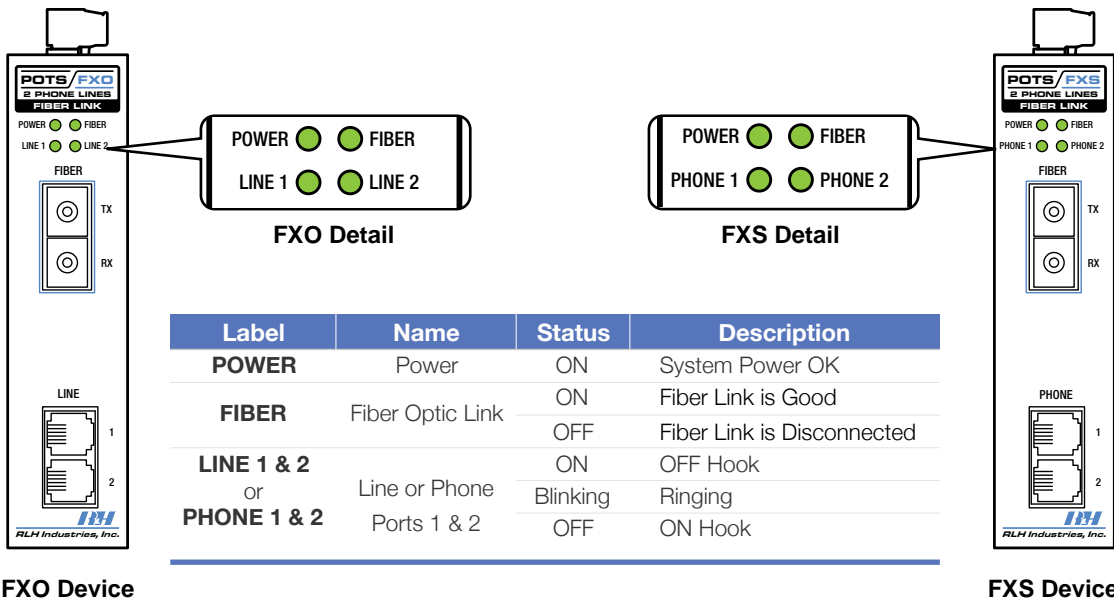

General Specifications

Fiber Connector Options	ST or SC		
Wavelength	Multimode	1310nm	
	Single-mode	1310nm/1550nm	
Maximum Fiber Attenuation / Distance*	Dual Fiber	Multimode (50/125µm & 62.5/125µm):	1.25mi./2 km range
		Single-mode (9/125µm):	12.4 mi./20km range
			37 mi./60km range
	Single Fiber, Bi-directional	Single-mode (9/125µm):	12.4 mi./20km range
			37 mi./60km range
<i>*Note: Distances equated using industry standard fiber and connector attenuation. Fiber condition, splices and connectors may affect actual range.</i>			
Phone Connectors	(2) RJ-11 Female		
Audio Bandwidth	300Hz to 3400Hz		
Analog Phone (POTS) Interface	FXO Device	Impedance	600 ohms
		Ring Frequency	Acceptable 20 ~50Hz
	FXS Device	Impedance	600 ohms
		Dial	DTMF and Pulse
		Battery Source	48VDC ± 4V
		Ring Voltage	80Vrms at 20Hz (Depending on the ringing load)
		REN	REN 3.0 (Ring Equivalence Number)
			*REN value is per channel.
Ringling Waveform	Sine wave		
Ring Cadence	FXS to FXS	On → 2 sec, Off → 4 sec	
	FXO to FXS	Reproduces the cadence detected by FXO	
Return Loss	40dB		
Supports	Caller ID & Call Forward Disconnect		
LED Indicators	Power, Fiber, Phone or Line 1~2 (See <i>User Guide</i> for more details)		
Power Input	24~48VDC or 125VDC nominal (Depending on model)		
	Dual redundant power inputs		
Power Consumption	FXO Device	2.5 Watts	
	FXS Device	5 Watts	
System Alarm Output	Normally Open / Closed Relay		
DC Input Isolation (In/Out)	1.5KV		
Voltage Reversal Protection	Will operate with V+ or V- in either power terminal		
Over Current Protection	1.0A (Automatic Recovery)		
Temperature	Storage	-40°C to +85°C (-40°F to +185°F)	
	Operating	-40°C to +70°C	
Dimensions	H 4.93" x W 1.20" x D 3.93" (not including DIN clip)		
Mounting	Includes standard T-35 DIN rail clip and wall mount ears		
Humidity	95% non-condensing		
Warranty	Limited Lifetime	Visit www.fiberopticlink.com for warranty details	

Ordering Information

Each 2 Channel POTS Fiber Link device is identified with a part number.

Optics	Distance	Fiber	Side	Type	Part Number
Multimode SC	2.4km / 1.5 mi.	62.5/50µm	-	FXO	PD-2FXO-03-1
				FXS	PD-2FXS-03-1
Multimode ST	2.4km / 1.5 mi.	62.5/50µm	-	FXO	PD-2FXO-04-1
				FXS	PD-2FXS-04-1
Single-mode SC (Single Fiber)	20km / 12.4 mi.	8~9µm	A	FXO	PD-2FXO-10-1
			B	FXS	PD-2FXS-11-1
	60km / 37 mi.	8~9µm	A	FXO	PD-2FXO-14-1
			B	FXS	PD-2FXS-15-1
Single-mode SC	20km / 12.4 mi.	8~9µm	-	FXO	PD-2FXO-40-1
				FXS	PD-2FXS-40-1
	60km / 37 mi.	8~9µm	-	FXO	PD-2FXO-41-1
				FXS	PD-2FXS-41-1
120km / 74 mi.	8~9µm	-	FXO	PD-2FXO-45-1	
			FXS	PD-2FXS-45-1	
Single-mode ST	20km / 12.4 mi.	8~9µm	-	FXO	PD-2FXO-50-1
				FXS	PD-2FXS-50-1
	60km / 37 mi.	8~9µm	-	FXO	PD-2FXO-51-1
				FXS	PD-2FXS-51-1
120km / 74 mi.	8~9µm	-	FXO	PD-2FXO-55-1	
			FXS	PD-2FXS-55-1	

- ▶ A complete system requires 2 devices of either configuration:
 - One (1) **FXO** device paired with one (1) **FXS** device for a typical phone line extension, or
 - Two (2) **FXS** devices paired for a ringdown hotline.
- ▶ Bi-directional single fiber models require an **A** Side and **B** Side unit for a complete system.
- ▶ Add **-A** to the end of the part number for 125VDC input power option.
- ▶ Please contact your RLH sales representative for pricing and delivery information.



RLH Industries, Inc.
 936 N. Main Street, Orange, CA 92867 USA
 T: (714) 532-1672
 F: (714) 532-1885

Please contact your RLH sales representative for pricing and delivery information.

Specifications subject to change without notice.