

# Fiber Optic Electrical Protection for Stand Alone PCS and Other Radio Sites

Bill Petersen – Protection Technologies Inc.

A vast majority of PCS cell sites are located on stand alone radio towers or atop various private buildings not associated with the power network<sup>1</sup>. In order to understand radio site electrical protection you must also understand the stress effects of lightning. After all, a radio tower is nothing more than a metallic lightning sucker<sup>2</sup>. Once it sucks in high frequency lightning currents the objective of protecting all electronic components (including workers) at the site is to insure the majority of lightning current passes around, rather than through, the facility into a low impedance grounding system. This paper addresses the basic principles for providing electrical protection for these facilities.

**Lightning protection configurations do not provide guarantees of any kind, only lower probabilities of being struck and receiving damage during any given storm!** The NFPA

(National Fire Protection Association) recommends, in their Lightning Protection Code 780<sup>3</sup>, the 150 foot rolling ball concept to provide effective protection to tall structures. Everywhere the sphere touches the structure there is a 100% probability it will be hit with lightning, and below the sphere the probability is reduced by 96%. In other words there will always be a small

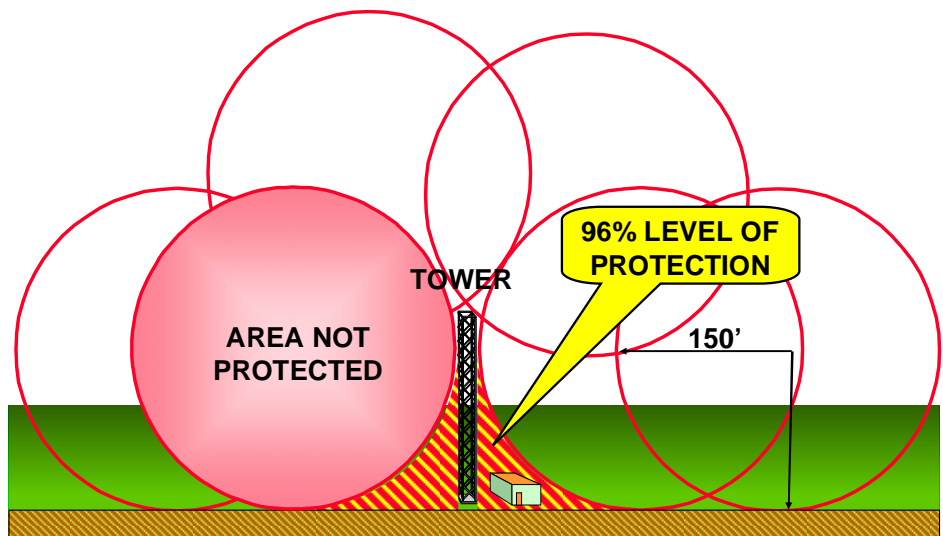

chance (4%) that regardless what type of protection is provided the facilities can and will be hit with lightning over a period of time. Here's my experience. There are two types of radio towers; those that have been hit with lightning, and newly built towers that will be hit in the near future! The objective is to minimize the level of lightning damage over the life of the site.

The NFPA rolling ball concept is based on lightning step leader jumping distances. These jump distances are a function of the length of the stroke, its current configuration and amplitude, and the ground impedance of the structure<sup>4</sup>. Due to the random characteristics of lightning the length of these step leader jumps will change with each individual strike.

On a tall tower above 150 feet, coax line grounding kits should be spaced every 75-100 feet. This will prevent side flashes between the tower and coax lines. If grounded guy lines are used to support a tower these additional grounding kits may not be required if the antennas fall inside the 4% area created by the down guys.

<sup>1</sup> For PCS radio sites located in, on, or adjacent to power substations and transmission lines refer to my white paper entitled, "Recommended practice for establishing Ground Potential Rise (GPR) and Zone of Influence (ZOI) Profiles"

<sup>2</sup> This is a non-technical term I use to explain, in basic terms, why lightning is attracted to tall metallic structures.

<sup>3</sup> NFPA 780: Standard for the Installation of Lightning Protection Systems, 2008 Edition

<sup>4</sup> Electrical Transmission and Distribution Reference Book by the Westinghouse Electric Corporation

Lightning has a wide variation in rise times (defined as the time in micro seconds it takes for the stroke to reach its maximum or crest value) and decay time (defined as the time it takes it to drop to half crest value.) In the example shown below an 8x20 (eight by twenty micro second) stroke would have a lot less energy, for a given amount of time, delivered to a structure. This type of lightning stroke is commonly referred to as **COLD**

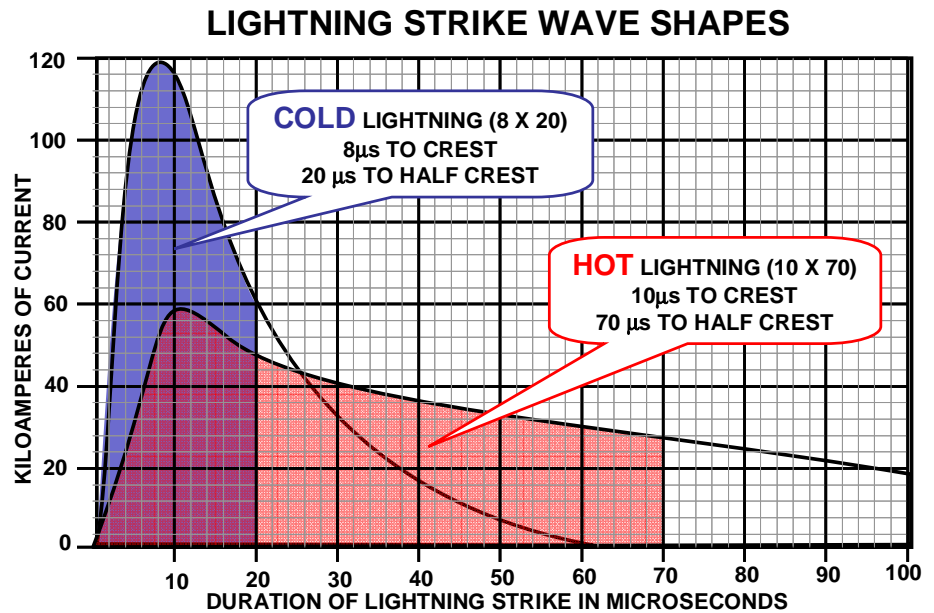

lightning<sup>3</sup>. Strokes of this type leave little traces of burning or fusing, but do develop explosive pressures in materials that are saturated with moisture. Strokes of this type turn water into steam rapidly and produce tremendous internal pressures (32,000 pounds/square inch typical). Examples of this are wood transmission towers and trees, and small concrete foundations that are not combined with external grounding systems. High intensity shock waves have been known to destroy the roofs of large flat buildings with the sonic high pressure waves they develop in a short time frame.

**HOT** lightning<sup>3</sup> generally has a lower crest value with extended half crest times. As can be seen, a 10x70 stroke would provide a lot more energy over a given amount of time. These strokes do not produce the explosive effects of cold lightning, but will ignite flammable materials (trees, wood towers and buildings) and fuse conductors that do not have sufficient current carrying capacity (cables, coaxes, ground leads, power conductors).

**All metallic conductors have self inductance.** This inductance stores energy in the form of a magnetic flux or field that is created as current passes through the conductor. Inductance is related to the magnetic flux lines and defined as Weber's (Wb). One Weber per Amp equals the inductance unit H (Henry). We're usually working in small units of Henry such as a μH. The transfer of energy into a magnetic field represents work performed by the power applied. Since power is current multiplied by voltage there is a voltage drop in the circuit while energy is being stored in the flux lines. This voltage drop, or difference, is the result of an opposing voltage induced in the metallic structure components while the field is building up to its crest value.

The amplitude of the voltage difference is proportional to the rate at which the current changes in time (Rise to Crest), and the length and configuration of the conductor. This value is expressed as inductance in Henrys (L)<sup>5</sup>. The voltage difference between any two points, expressed as a function of lightning rise time, can be determined with the following relationship:

$$\text{STRESS VOLTAGE} = L \frac{di}{dt} = \frac{\mu\text{H} \times \text{Amps}}{\mu\text{Seconds}}$$

<sup>5</sup> The basic mathematical concepts used today for inductance are derived from the works of Frederick W. Grover who published various classical references from 1918 to 1973. Most of his calculation tables have been reduced to simpler terms, as offered here, that can be applied by the working engineer.

The inductance of coax cables and single wire gauges in  $\mu\text{H}$  can be calculated using the formulas shown here. These values are controlled by two variables; the length of the coax or wire, and their diameter in inches. Some common values are given for various types of conductors used today for radio and electrical protection. The formulas become somewhat more complicated for grounding straps due to the skin effect and higher aspect ratio (thickness to width) at higher lightning frequencies. Notice that a 26 AWG (0.016)" x 1.5" wide strap has about the same inductance value as a round 750mcm conductor. This can be of economic importance in trying to reduce voltage stress levels at radio sites.

### INDUCTANCE OF WIRE ( $\mu\text{H}$ )

$$5.08 \times 10^{-3} \left[ \ln \left( \frac{4L}{D} \right) - 0.75 \right] L$$

L = LENGTH, D = DIAMETER IN INCHES

WIRE SIZE DIAMETER IN INCHES	5	10	15	20	25	30	35	40	45	50
750mcm	0.998	1.44	3.31	5.33	7.46	9.67	11.93	14.25	16.61	21.45
350mcm	0.681	1.56	3.54	5.68	7.93	10.25	12.63	15.07	17.55	22.61
4/0	0.460	1.68	3.78	6.04	8.41	10.85	13.35	15.91	18.5	23.81
2/0	0.365	1.75	3.92	6.25	8.69	11.2	13.77	16.4	19.07	24.51
#2	0.257	1.86	4.14	6.57	9.12	11.74	14.42	17.15	19.92	25.58
#6	0.162	2.0	4.42	7.0	9.68	12.44	15.26	18.13	21.05	26.99
#10	0.102	2.14	4.7	7.42	10.24	13.14	16.11	19.12	22.18	28.4
#12	0.081	2.21	4.84	7.63	10.52	13.5	16.63	19.61	22.74	29.1
#14	0.064	2.28	4.98	7.85	10.81	13.85	16.96	20.11	23.31	29.82
D"										

**Towers are struck by lightning more than any other communication site.** In order to minimize lightning currents from damaging equipment in a building it is imperative that the tower, and its associated electronic equipment, have an equalized low impedance path to true earth<sup>6</sup>! At lightning frequencies (DC to 100MHz) inductance, not resistance is of primary importance. Note: The NEC<sup>7</sup> (National Electric Code) is based on 60 Hz with a wavelength of around 3,000 miles. The 100 MHz high end frequency of lightning has a wavelength around 10 feet long. If the NEC is used as the only criterion for electrical protection for a radio tower lightning damage levels will rise substantially.

To determine the inductance of a tower you can use radio 1/4 wavelength formulas or high end computer programs; a lengthy process<sup>8</sup> that requires a lot of time to derive approximate inductance

### INDUCTANCE OF COPPER GROUNDING STRAPS (mH)

$$5.08 \times 10^{-3} \left[ \ln \left( \frac{2L}{W+T} \right) + 0.5 + \left( \frac{0.2235(W+T)}{L} \right) \right] L$$

L = LENGTH, W = WIDTH, T = THICKNESS (0.016) INCHES

WIDTH OF STRAP	5	10	15	20	25	30	35	40	45	50
6"	1.07	2.56	4.21	5.96	7.78	9.67	11.61	13.59	15.61	17.67
3"	1.28	2.98	4.83	6.8	8.83	10.93	13.08	15.27	17.51	19.77
1.5"	1.49	3.39	5.46	7.63	9.88	12.19	14.55	16.95	19.39	21.87

### INDUCTANCE OF COAX CABLES ( $\mu\text{H}$ )

$$5.08 \times 10^{-3} \left[ \ln \left( \frac{4L}{D} \right) - 0.75 \right] L$$

L = LENGTH, D = DIAMETER IN INCHES

COAX DIAMETER	10	25	50	75	100	125	150	175	200	225	250	275	300
3"	2.6	8.0	18.1	29.0	40.4	52.2	64.3	76.7	89.3	102.0	115.0	129.1	141.3
2"	2.9	8.6	19.3	30.8	42.9	55.3	68.0	81.0	94.2	107.6	121.2	134.9	148.7
1-5/8"	3.0	8.9	20.0	31.8	44.1	56.9	69.9	83.2	96.8	110.5	124.3	138.4	152.5
1-1/4"	3.2	9.3	20.8	33.0	45.7	58.9	72.3	86.0	99.9	114.1	128.3	142.8	157.3
7/8"	3.4	9.9	21.8	34.6	47.9	61.6	75.6	89.8	104.3	119.0	133.8	148.8	163.9
1/2"	3.7	10.7	23.6	37.2	51.3	65.9	80.7	95.8	111.1	126.6	142.3	158.1	174.1

<sup>6</sup> W. Ruan, R. Southey, F.P. Dawalibi, N.A. Idris; *Application of the Electromagnetic Field Method to Study a Communication Satellite Site Damaged by Lightning*

<sup>7</sup> ANSI C2 National Electric Safety Code, by The Institute of Electrical and Electronic Engineers and the American National Standards Institute.

<sup>8</sup> G. Lian, W Shumin, Z Guofu; *An Approximate Approach for the Inductance Coefficients of an Electric Circuit Containing a Number of Branches*

( $\mu\text{H}$ ) values. Or, you can use this empirical formula to obtain usable results:

$$\text{Tower inductance } (\mu\text{H}) \approx 0.256 \times (\text{Tower Height in feet})$$

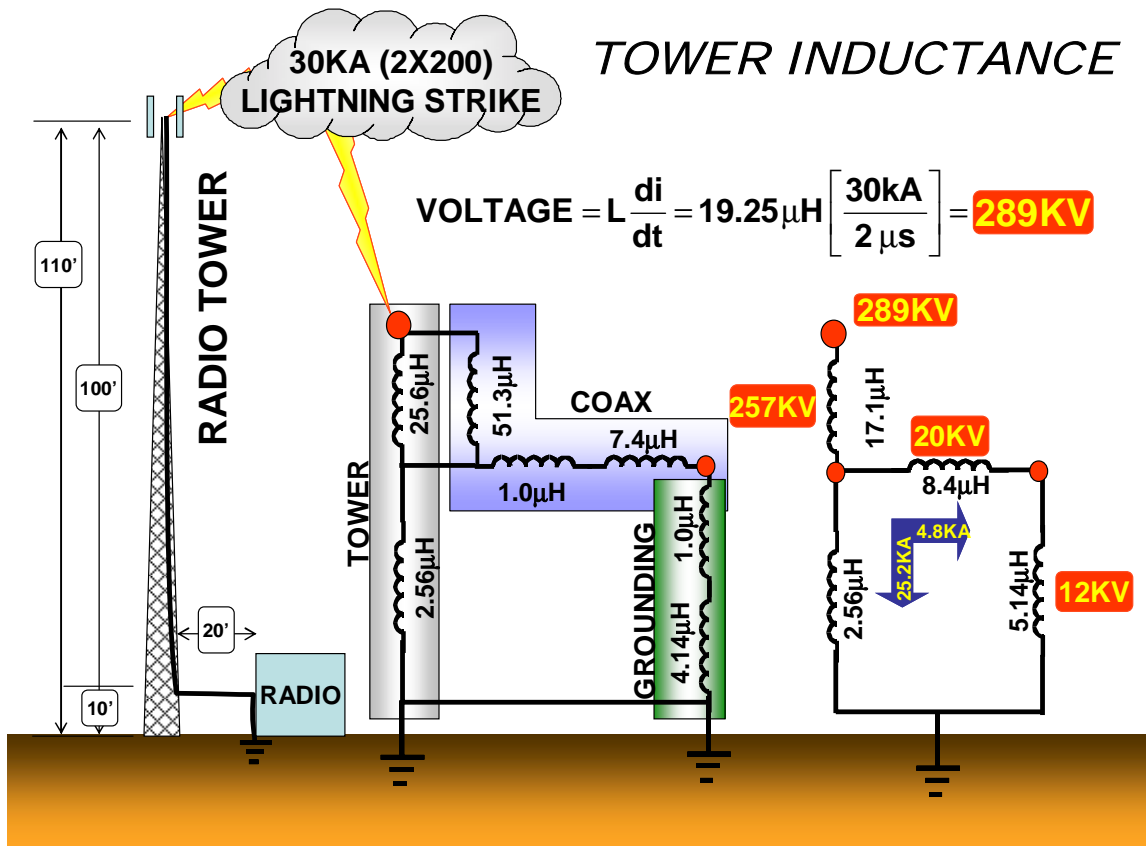

As an example: If a 1/2 inch coax runs down a 110' tower, leaves the tower at 10' above the ground using a coax grounding kit, travels 20' to the radio building single point bulkhead, and is grounded to earth using a single #2 copper wire, the total inductance would be as follows:

- Coax 100' from top of tower  $\approx 51.3\mu\text{H}$
- Bend at bottom of tower ( $1.0\mu\text{H}$ ) + 20' ( $7.4\mu\text{H}$ )  $\approx 8.4\mu\text{H}$
- Bend at the bulkhead ( $1.0\mu\text{H}$ ) + 10' #2 ground wire ( $4.14\mu\text{H}$ )  $\approx 5.14\mu\text{H}$
- Tower inductance =  $110 \times 0.256 \approx 28.16\mu\text{H}$  (split into  $25.6\mu\text{H}$  and  $2.56\mu\text{H}$ )
- Combined parallel path inductances  $\approx 19.25\mu\text{H}$

Hitting the tower with an "average every day" 30kA (2 x 200) lightning strike develops a voltage difference of 288,750 volts from the top of the tower to the grounding field. This voltage difference is split in proportion to the individual inductance paths, resulting in a peak stress voltage across the equipment of approximately 12KV!

**Caution:** Do not place additional ground leads on a tower for coax cable grounding kits. Attach the ground bars associated with these devices directly to the tower; do not use stand off insulators. It is a crucial design consideration, for all radio tower grounding schemes, that the lowest inductive path from the top of the tower to ground will always be the metallic structure itself. The overall objective of the electrical protection design relies on conducting a major portion of the lightning current (25.2kA) directly into the tower ground rather than the equipment (4.8kA) ground.

If you were to look at lightning as if it were a bucket of water being poured on top of a radio tower (in reality electrons do have mass) this is what you would see. When it first hits, the lightning current will move outward from the tower grounding ring along its associated radials. This includes the single bonding connection to the BTS ground ring.

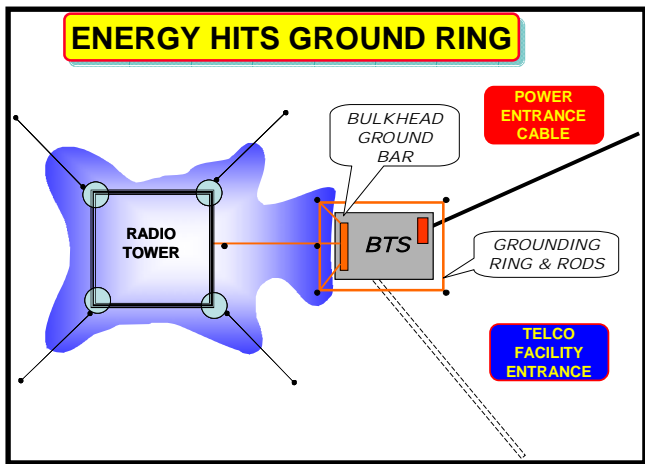
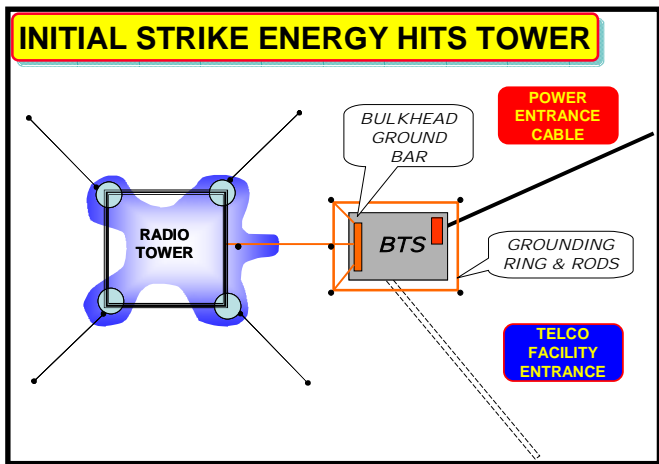

On a properly installed grounding system the lightning energy will initially spread out along the building side where the main coax bulkhead panel is located. Notice that at this point in time there will be a high potential at the bulkhead and a low potential on the opposite side of the structure being protected. This is where ground loops develop high voltage differences that can damage equipment and present a hazard to workers. If the tower ground field is designed and installed to provide very low impedances for the soil conditions at the site, most of the lightning energy will saturate into the earth around the tower before it traverses the radio building. Again, this is the primary objective.

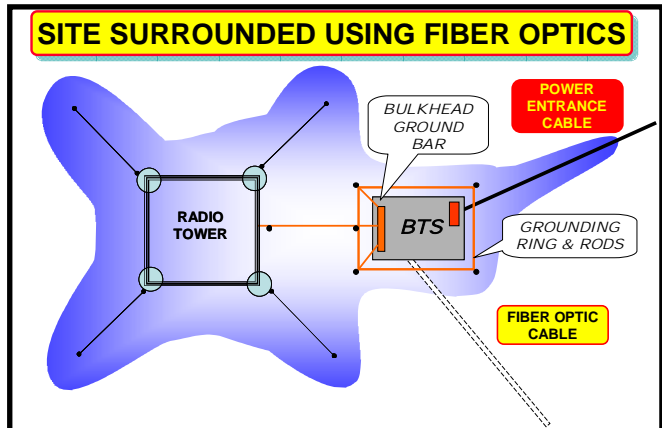
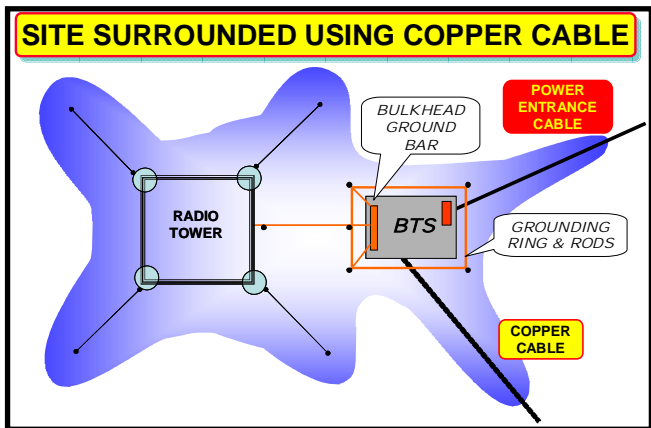

By the time the lightning current surge has surrounded the radio building, the tower grounding ring and associated radial systems should have spread out or distributed much of the current. With the site surrounded by a lightning surge it becomes obvious that feeding the site with copper based cable facilities becomes an electrical protection issue. From a communications point of view, a considerable amount of safety and reliability can be built into a radio site by providing a fiber optic link for all backhaul circuits.

**Grounding loops** that can carry lightning fault currents through equipment, and or provide dangerous voltage differences to workers, and should be avoided at all cost! The ideal situation would be to create a low impedance grounding system that connects directly to the bulkhead single point ground. Alternatively, the bulkhead could also be attached to the site's Master Ground Bar (MGB) as outlined below.

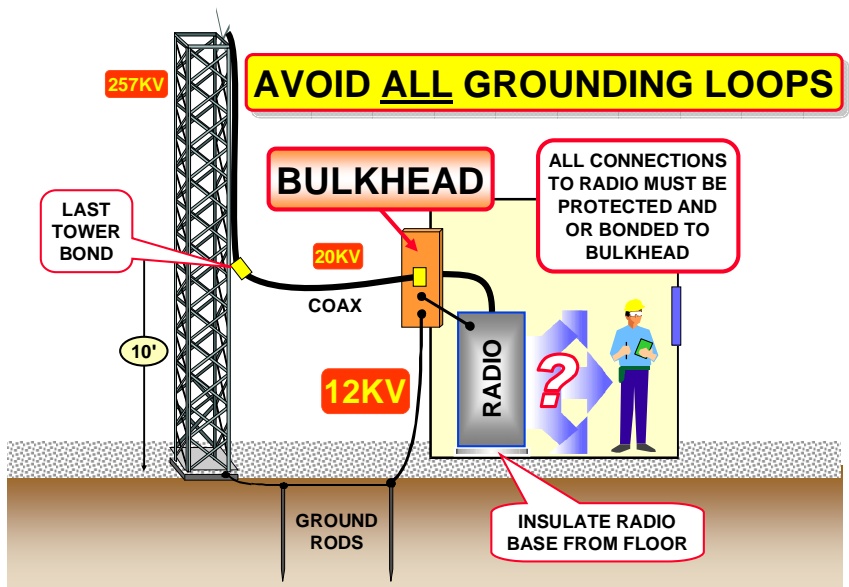

In the previous example, where the coax left the tower 10 feet above the ground, there would be a 12KV potential appearing at the bulkhead. If the equipment has a separate path to ground, such as the safety ground of the power system or telephone cable pairs and shield, then this path will allow strike current to flow through the equipment chassis causing failures. **This is also a safety hazard for those that may be working in, on, or around the radio facilities!**

Where individual equipment racks are used they should be isolated from the building structure and be grounded in the same manner as an electronic switch that requires a single point ground plane. In this case the ground window would appear at the same location as the bulkhead rather than run up the center of the bays as is commonly done in larger Central Offices.

A Master Ground Bar (MGB), placed at a radio site, must have the bonding and grounding circuits attached so transient currents are conducted to earth rather than through the components being protected. If not properly sequenced, a common grounding bar will create, rather than eliminate, stray current loops throughout the communications site. The objective is to combine the ground fields together in a sequential manner so that they conduct currents to ground rather than setting up a Ground Potential Difference (GPD) and or  $V=Ldi/dt$  condition within the buss bar at lightning frequencies.

### MASTER GROUND BAR SEQUENCING

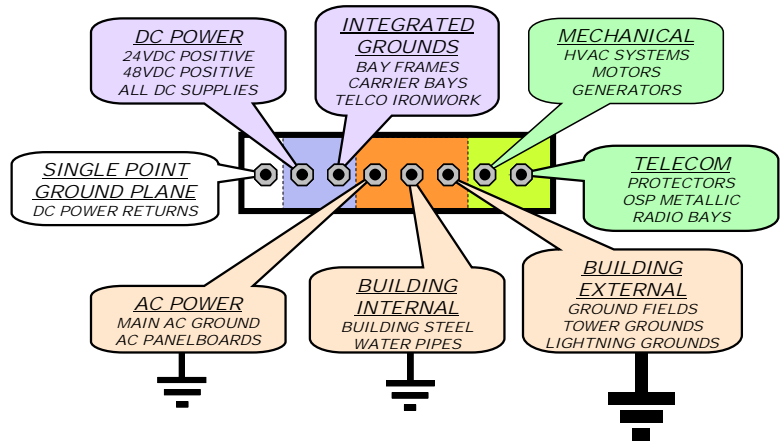

Placing the earth grounding systems together provides an energy grounded sink as well as a grounding barrier for the circuits bonded to it. If properly designed and installed, sequenced grounding system will not allow lightning transient currents to pass from one side of the bar to the other. Notice that the items on the right side will only be conducting energy during abnormal protection conditions. The items to the left will have current flowing through them under normal working conditions.

To prevent an electrical protection disaster from occurring, a low impedance grounding system must be created and connected together at the base of the tower. A lightning strike contains a given amount of energy. Most of the energy should be divided and dispersed by the tower ring and radial grounds before the remaining energy is absorbed by the communications grounding system. It is important that all single point bulkhead grounds be bonded at the end of the Master Ground Bar as shown here. If it is placed at any other location the single point ground concept will be greatly compromised! **Again, it is highly recommended that the bulkhead panel serve as the primary system single point ground reference at radio sites.**

**But, what about the transferred potentials of remotely grounded power and communication facilities?** All of these installations will be powered via a locally derived AC power source carry a neutral or remote ground reference with it. Due to the larger cable sizes involved, and the fact that under fault conditions the AC power supply protectors will operate and provide additional current carrying capacity to remote earth, most of the lightning current remaining will split in proportion to the impedance of the remaining external paths. If the site is serviced with a copper telephone cable a portion of that current will follow the cable to remote ground. **If a non-metallic fiber optic cable is used then none of the current will follow the communications link back into the serving communication system (local telco facilities).**

**Transferred potential<sup>9</sup>** is the special case of touch potential where a voltage is transferred into or out of a radio station. Typically, transferred voltage occurs when a person standing within the station area touches a conductor grounded at a remote point, or a person standing at a remote point touches a conductor connected to the radio site grounding grid. The two most common external conductors are AC power and copper based telephone cables. **Whenever practical, metallic telecommunications lines should be eliminated from all radio towers. Metallic (copper based) telecommunications/data lines provide a conductive path out of and into the facility for lightning energy. It can come from either direction. Eliminating metallic telecommunication lines with the use of fiber optic cable provides isolation from lightning-induced ground potential rise (GPR) and lightning energy.<sup>10</sup>**

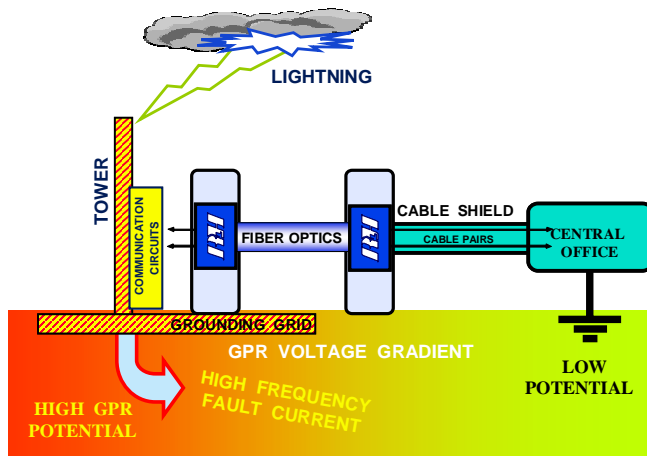

During lightning and or power fault conditions it is impractical, and often impossible, to design a ground grid based on the touch voltage created by external transferred voltages<sup>9</sup>. Hazards from these external transferred voltages are best controlled by using electric power protection devices that equalize, ground, or isolate through properly designed interfaces.

In the previous examples shown each tower radial carries a high proportion of the current, the main objective is to have most of the lightning energy dumped into the earth by the tower grounding system. The remaining energy will be distributed to the radio via a single bond wire placed in the ground between the two ground systems. Note that this single bond wire does not contain additional radials. Its main function is to equalize the potentials between the tower and radio and not to provide a low impedance path. If multiple low impedance conductors are placed between the tower and radio electronics, instead of this single wire, then a greater

<sup>9</sup> IEEE Std 80, *IEEE Guide for Safety in AC Substation Grounding*

<sup>10</sup> Motorola R56 *Standards and Guidelines for Communication Sites*

proportion of the lightning current could travel towards the radio facilities. This also applies to bond an ice bridge to the radio tower. Higher lightning currents will flow towards the radio equipment when multiple current paths are created. This is not the result desired!

A perimeter ring ground around the building reduces the amount of touch and step voltage<sup>11</sup>. If a "halo" ground is utilized, for the reduction of EMP pulse energy created by the lightning strike, it must be attached to the ring ground but not directly to the bulkhead. The objective here is to put this energy directly into the earth, at the base of the bulkhead, without creating additional voltage rises through the bulkhead area.

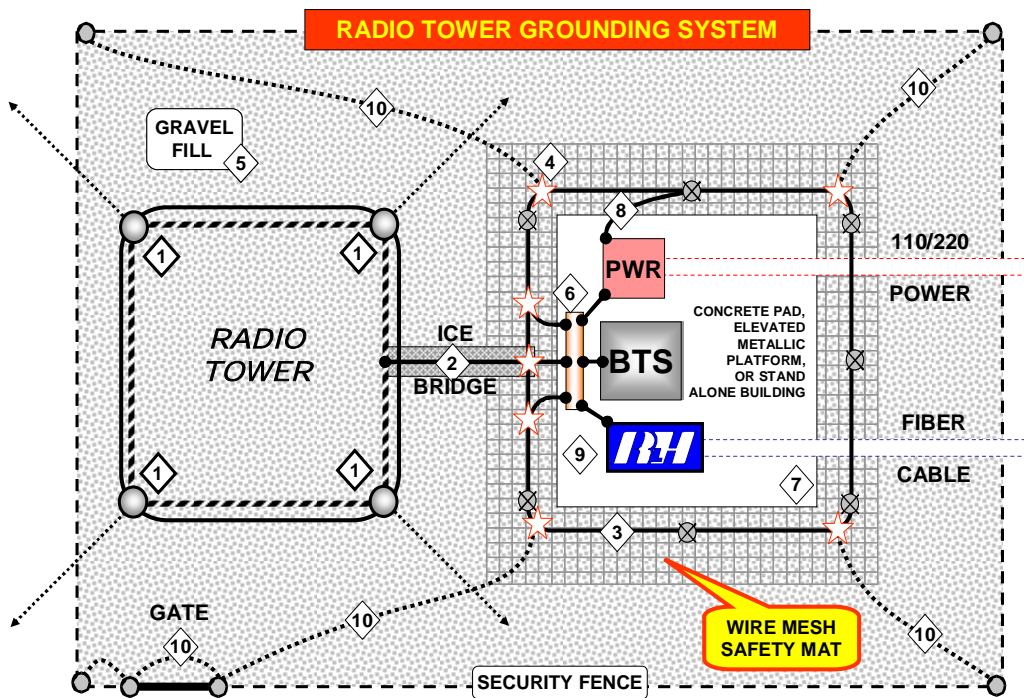
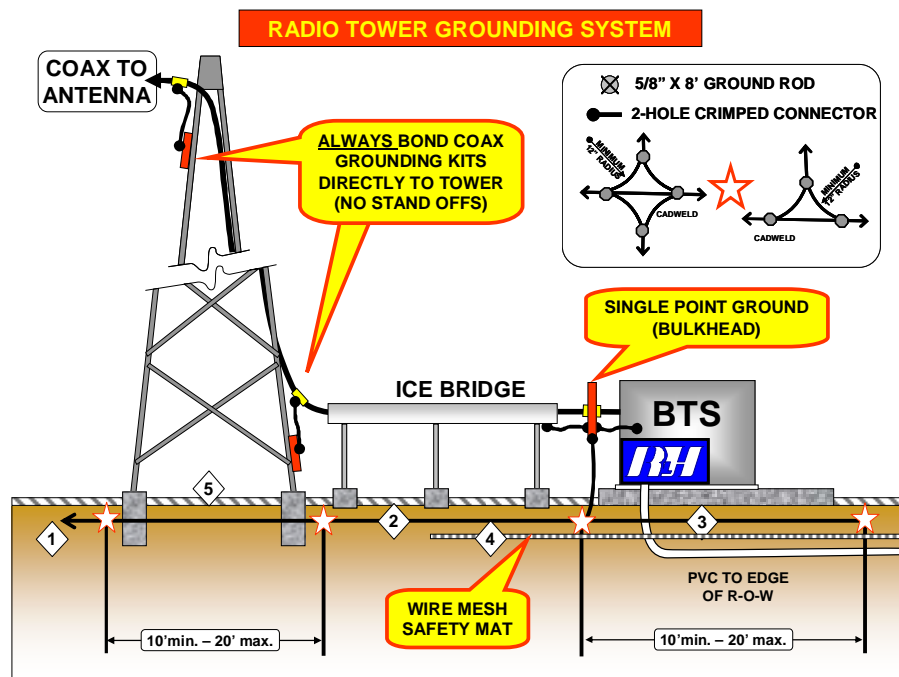

<sup>11</sup> IEEE Std 80, IEEE Guide for Safety in AC Substation Grounding

### **Touch, step, and mesh voltage.**

The following notes correspond to the small numbered diamonds shown on the previous two figures depicting side and overhead views of a stand alone radio tower installation.

**1 – RADIO TOWER FOOTINGS.** At these specific locations it is recommended that an additional 2 AWG bare solid tinned copper wire ground ring be placed at a 24" depth and bonded to each tower leg with a listed bond. If a counterpoise is required, due to poor soil resistivity, extend a 2 AWG solid tinned wire approximately 30 ft-50 ft from each corner with ground rods (if possible) placed at each end and at 20' intervals. The recommended depth of the counterpoise wire is 24" and shall not contact any other metallic components at the site (i.e., fences). This will reduce touch and step potential.

**2 – ICE BRIDGE BOND.** When the BTS radio is placed to the side of the power tower the ice bridge should not be bonded to the tower structure here! It should only be bonded at the bulkhead for equalization purposes. This will reduce touch and step potential.

**3 – BTS GROUNDING RING.** Place a 2 AWG bare solid tinned copper wire within 3 ft (+/- 15% tolerance) from edge of the concrete pad, elevated metallic platform, or building at a maximum depth of 2 ft. Ground rods must be placed a minimum of 3 m (10 ft) apart and or at each corner of the ground ring. This will reduce touch and step potential when the ring is bonded to the mat in item 4 below.

**4 – WIRE MESH SAFETY MAT.** It is recommended at joint use power towers that a wire mesh safety mat (6" on center) be bonded to the ground ring and extended a minimum 6' from the edge of the pad or tower foot print, whichever is the greatest distance. This will reduce touch, step, and mesh potential when covered with gravel fill as described in item 5 below.

**5 – GRAVEL FILL.** For worker safety and to decrease step potential, a layer of clean crushed gravel a minimum of 3 "– 6" deep should be placed over the entire grid/mesh area. When a security fence is in place the clean crushed gravel should be placed within the total security fence area. See IEEE-80 for design details. **For worker safety reasons do not use conductive asphalt for this application as conductive asphalt will increase touch and step potential.**

**6 – BULKHEAD GROUND BAR.** The bulkhead is the single point ground for the installation. All equipment or secondary protectors that require a ground or ground reference shall be bonded to this single point, either directly or with the use of a Master Ground Bar (MGB) located within 3 ft. of the bulkhead. Use individual listed grounding kits for each coax cable entering the BTS at this location. This will reduce touch and step potential for workers and provide voltage equalization for equipment at the site.

**7 – CONCRETE PAD, ELEVATED METALLIC PLATFORM, OR STAND ALONE BUILDING.** If a concrete pad contains rebar and or wire mesh it shall be equipped with external bonding connectors and bonded to the ground ring at a minimum of two opposing corners. If the BTS is placed on an elevated metallic platform or stand alone building it must also be bonded to the ground ring at a minimum of two opposing corners. The bonding wires must be a minimum 6 AWG copper wire. This will reduce touch, step, and mesh potential and provide voltage equalization for equipment at the site.

**8 – AC POWER ENTRANCE PANEL.** Commercial ac power service entrance cables must be placed in a PVC conduit (suitable for power cable pulling) at a minimum depth of 3 ft. to a point beyond the tower Zone of Influence (ZOI). The entrance panel must be bonded directly to the ground ring at its closes location. If properly installed the BTS ring ground meets or exceeds the

NEC Article 250 utility protection ground. If local codes require an additional ground rod, bond the ground rod to the ground ring. All power circuits that enter the BTS must be provided with primary (placed on the line side of the serving panel board) and secondary (placed on the load side of each 20A. circuit) protection. Some BTS manufactures provide secondary protection within their equipment that meet the secondary requirement. All secondary green wire safety conductors must be placed within 3 ft. of, and bonded to, the bulkhead or MGB with a copper conductor sized per NEC Article 250-122.

**9 – HIGH VOLTAGE PROTECTION (HVP).** Fiber optic cables must be placed in a PVC conduit (suitable for communication cable pulling) at a minimum depth 2 ft. to a point beyond the tower Zone of Influence (ZOI). Secondary protectors on the copper drop side of the fiber interface at the BTS shall be placed directly on, or bonded within 3 ft. of the bulkhead. This will reduce touch potential and greatly decrease lightning caused equipment failures.

**10 – FENCE AND GATE EQUALIZATION BONDS.** Use 2 AWG solid tinned copper wire exothermically welded to the ground ring and attached to each inside or outside corner fence post, and or gate post, with a listed wire clamp. Place at a minimum 12" depth. Wherever practical, due to magnetic coupling with the tower counterpoise wires (if used), cross at a 90° angle while maintaining a minimum 12" vertical separation. Do not bond these two grounding systems together at crossings. Place a 2 AWG solid tinned copper wire attached to each gate post with a listed wire clamp. Place a flexible bonding strap from each gate post to the movable gate section(s) with listed clamps. If the metallic posts are not set in concrete place an additional ground rod at each post location. This will reduce touch potential.

**Additional requirements for roof top radio sites**

There are two additional electrical protection requirements when placing a PCS, or any radio system, on top of an existing building. You must also provide a low impedance lightning energy path to ground and a fiber optic communications link for the backhaul circuits.

**Provide a low impedance grounding path.** The major difference between roof top and ground level installations is the availability of a ground. **It is vital that it be low impedance and run in a very short direct path! In the order of their lowest impedance and electrical protection preference (a through f) use the following grounding conductors:**

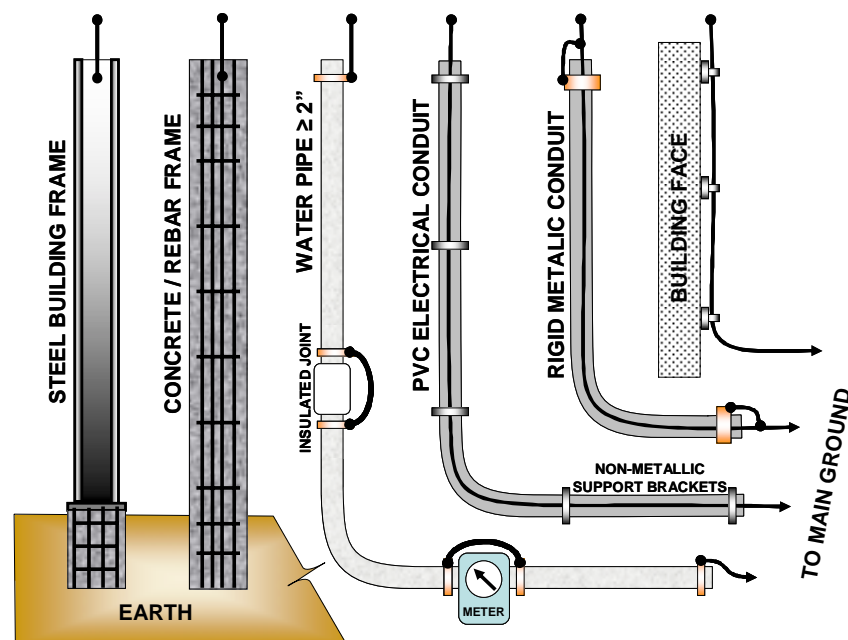

- a – Steel frames and their supporting concrete or steel pilings provide the lowest impedance to ground and should always be the first choice for the primary grounding conductor.
- b – Concrete based frames and their supporting steel rebar cages also provide low impedance to ground, but should be two point tested for continuity before they are used for the primary grounding conductor.
- c – A  $\geq 2"$  diameter metallic water pipe may be used as a grounding conductor if it is certified to be electrically continuous from the BTS to the building ground or municipal water system.
- d – A grounding conductor may be placed in a schedule 80 PVC pipe (using non-metallic support brackets) if it is not placed parallel to other metallic piping systems.
- e – A grounding conductor may be placed in a rigid metallic conduit if it has "listed" grounding bushings placed where it enters and exits the conduit.
- f – An external grounding conductor may be placed on a non-metallic building face using non-metallic support brackets. If the face is metallic, and can be certified as electrically continuous, use it like a steel building frame.

Keep in mind that a roof top radio system has now been turned upside down, placing it in the highest lightning exposure area. The 150 foot rolling ball concept dictates that everywhere the sphere touches the structure there is a 100% probability it will be hit with lightning, while the interior of the building the probability is reduced to 4% or less depending on the building structure. Standard copper based communication cables will be subjected to the same high level of lightning voltage as coax cables on stand alone towers. Unfortunately they are not protected in the same manner. Fiber optic cables are immune to lightning voltage differences and immune to Electro Magnetic Pulse (EMP) induction as well.

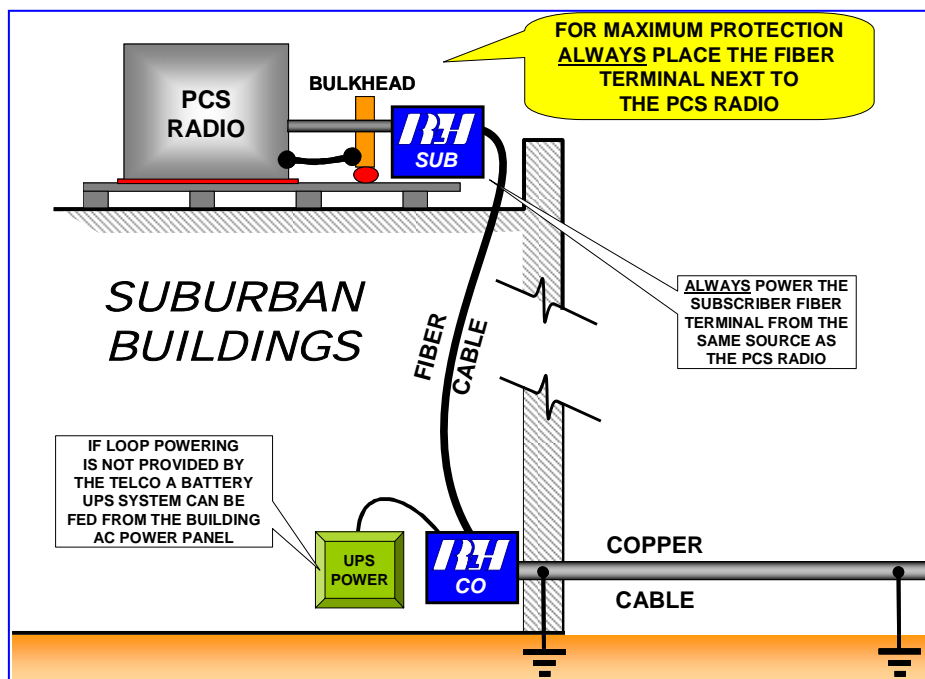

**Always provide fiber optic communications** to the base of the building in suburban locations, and extended external to the building in rural locations. In suburban areas the building will

always be bonded to the massive metallic infrastructure surrounding it. This may not be true for a building located in a rural area. A rural building may have a lightning GPR condition and require an extended fiber cable beyond its ZOI.

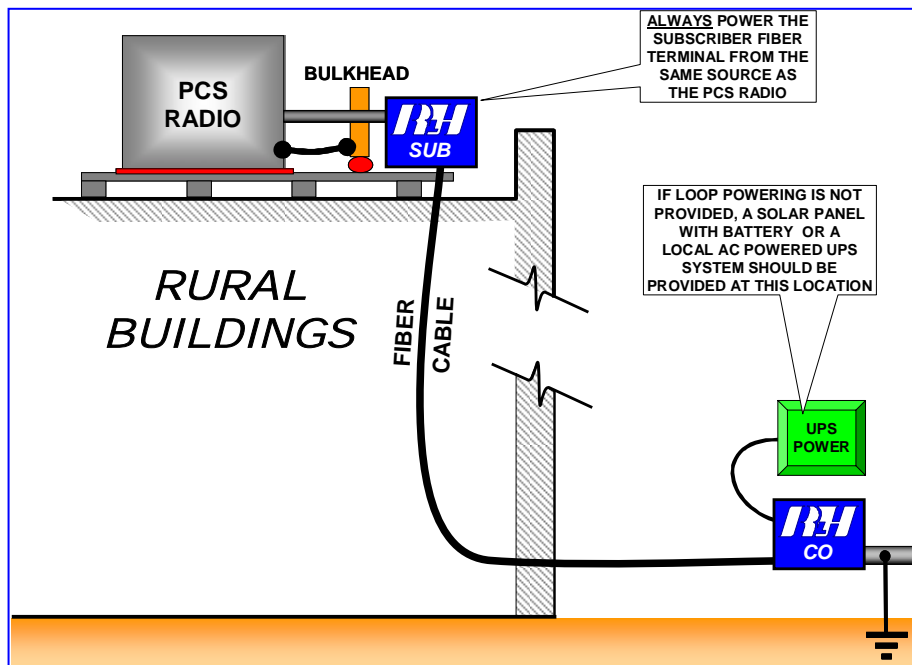

Another advantage for using a fiber link on roof top installations has to do with the transmission of DS-1, or higher bit rates, over Cat-5 copper cables. A fiber link eliminates these restrictions, and allows backhaul circuit extensions regardless of the building height.

### Economic considerations for using fiber optic links at PCS and other radio sites

PCS (Personal Communications Services) provider's MSC (Mobile Switch Center's) connect to their local BTS' (Base Transceiver Stations) using high bandwidth digital communication links.

These digital links, referred to as BACKHAUL, provide transmission paths within the PCS network and access to the PSTN (Public Switched Telephone Network) while also performing complicated user call authentications, completions, handoffs between cells, and billing functions. The objective within this industry is to keep each and every cell site operational at all times in order to maximize minutes of use.

From an economic and reliability point of view here are a few facts to consider (U.S. wireless markets as of June 2008; M=Million, B=Billion, T=Trillion):

<b>Subscribers</b>	<b>262.7 M</b>	<b>Number of cell sites</b>	<b>220,472</b>
<b>Population use</b>	<b>84%</b>	<b>Minutes of use</b>	<b>2.23 T</b>
<b>Wireless only homes</b>	<b>15.8%</b>	<b>Annual revenues</b>	<b>\$143.7 B</b>
<b>Direct jobs</b>	<b>268,000</b>	<b>Annual investment</b>	<b>\$21.0 B</b>
<b>Direct wages</b>	<b>\$13 B</b>	<b>E-911 calls per day</b>	<b>296,000</b>

While a radio site is down revenue is lost! (\$0.5M – \$2.0M per site per year)