



RLH Industries, Inc.

Advantages of using a Fiber Optic Contact Closure System

2010A-0513

Advantages of using a Fiber Optic Contact Closure System

The RLH Fiber over Contact Closure system is an industrial grade solution for both short and long haul remote on/off applications.

The Contact Closure over Fiber system provides an optical-to-electrical interface between one (simplex) fiber strand and normally-open relay contact output. This versatility makes this system a favorite for security applications, manufacturing and machinery applications such as used the energy and mining sectors, or anywhere that you need to operate an on/off switch over extended distances or in hazardous environments.

The advantages of using a fiber optic contact closure system include:

- Hardened reliability suitable for critical safety or emergency shut-down (ESD) applications.
- High noise immunity of contact signal, particularly beneficial in electrically noisy environments and over long distances.
- Designed for industrial applications: Available as a 4RU plug in card, stand alone unit or DIN rail model with integrated power supplies.
- Optical fiber Isolates equipment from generated RF noise and voltage spikes.
- Eliminates the formation of ground loops when two devices are connected to separate power lines or have a difference between their ground voltage potentials.
- Total isolation and protection of signal processor's input stage from accidental sensor malfunction (e.g. short to mains voltage or a lightning shock).
- Replaces bulky coaxial cables with compact fiber optic cables - especially important when rewiring existing ducts.
- Up to 8 individual contact closure signals may transmitted over a single fiber.
- Interfaces to existing fiber cable – Multi Mode or Single Mode.
- Long distance transport of signals: Multimode (62.5/125 μ m, 50/125 μ m): 2.0 miles/3.4km; Single-Mode (9/125 μ m): 9 miles/15km; Long Haul 37 miles/60km.

Typical 4 Channel Contact Closure over Fiber Connection Diagram

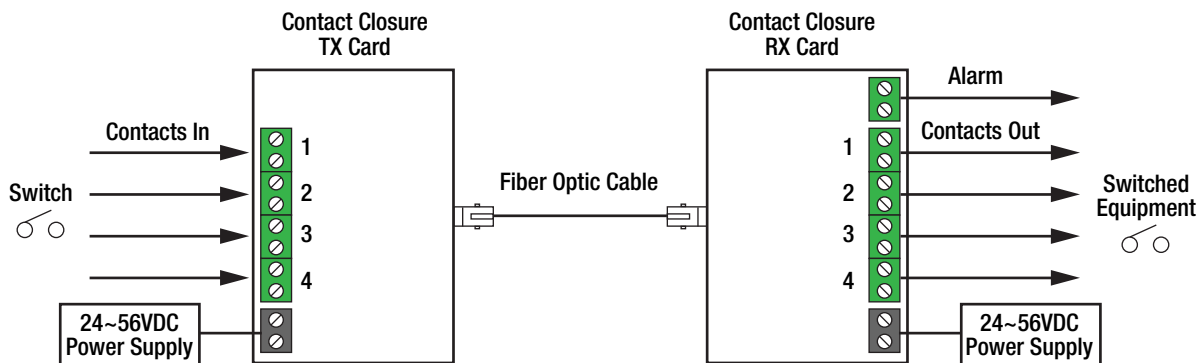

Refer to the product data sheet for additional information.

Specifications subject to change without notice.