

RLH 48V 10A Solar Power Charge Controller

Solar Power Battery Charge System

Introduction

The RLH 48V 10A solar power charge controller is a fully integrated solution designed to provide remote powering for industrial equipment. RLH solar power charge controllers are engineered to be durable and highly efficient.

The charge controller continuously maintains the correct charge level on a 48V lead acid type backup battery, such as the RLH 7Ah 48V battery pack, and ensures a seamless power transition to battery power when needed. The charge controller allows maximum solar array current to flow into the batteries, and the temperature sensor adjusts the charging current based on ambient conditions.

The control circuit uses a MCU (microcontroller) with imbedded software for intelligent system control. Charging mode uses PWM (pulse-width modulation) for high efficiency. Boost, recovery and float charging are managed automatically along with built in temperature compensation to maximize battery life.

The battery discharge rate is accurately controlled, and the over-discharge voltage is continuously modified by the battery discharging rate curve.

Overload, external and internal short circuit, reverse connection, lightning, PV panel reverse current, over charging and discharging protection is built-in. In the event of a short circuit or overload event, the system will be protected and remain undamaged.

Front panel LED indicators show status, and several different work modes may be set by the end user.

The 48V 10A Solar Power Charge Controller is covered by our **Exclusive Unconditional Lifetime Warranty**



48V 10A Solar Charge Controller

Contents

Introduction	1
Key Features	2
General Safety Practices	2
Acronyms	3
System Diagram	3
Installation	4
Operation	5
Setting Modes	6
Troubleshooting	7
Ordering Information	7
Specifications	8
Warranty	9
Technical Support	9

Key Features

- Complete solar power solution designed to work with photovoltaic panels and 48 V backup battery.
- Compact size is easy to mount on wall or panel
- Charge controller maintains batteries in optimum condition
- Built-in battery test function
- Convenient screw terminals for wiring
- Connections for PV panel, battery and load
- Built-in overload and short circuit protection
- Automatic self-recovery after fault removal
- LED system status indicators
- Requires no adjustments
- Settings are digitally retained in onboard flash memory
- User selectable on, off, priority, and time modes
- Wide operating temperature range -35°C ~ +50°C (-31°F ~ +122°F)
- Exclusive Unconditional Lifetime Warranty

General Safety Practices

Intended Audience

This guide is intended for use by knowledgeable telco/network installation, operation and repair personnel. Every effort has been made to ensure the accuracy of the information in this guide is accurate. However, due to constant product improvement, specifications and information contained in this document are subject to change without notice.

Conventions

Symbols for notes, attention, and caution are used throughout this manual to provide readers with additional information, advice when special attention is needed, and caution to prevent injury or equipment damage.

The equipment discussed in this document may require tools designed for the purpose being described. RLH recommends that service personnel be familiar with the correct handling and use of any installation equipment used, and follow all safety precautions including the use of protective personal equipment as required.

Caution - Severe Shock Hazard

- Never install during a lightning storm or where unsafe voltages are present.
- Solar panels produce power when exposed to light. Use caution when handling copper wiring.
- Do not use with equipment that exceeds the rated power for this device.

Acronyms

Commonly used acronyms and abbreviations

Acronym/Abbreviation	Description
PV	Photovoltaic Panel (Solar panel array)
LED	Light Emitting Diode
MCU	Microprocessor
PWM	pulse-width modulation
AWG	American Wire Gauge wire diameters

System Diagram

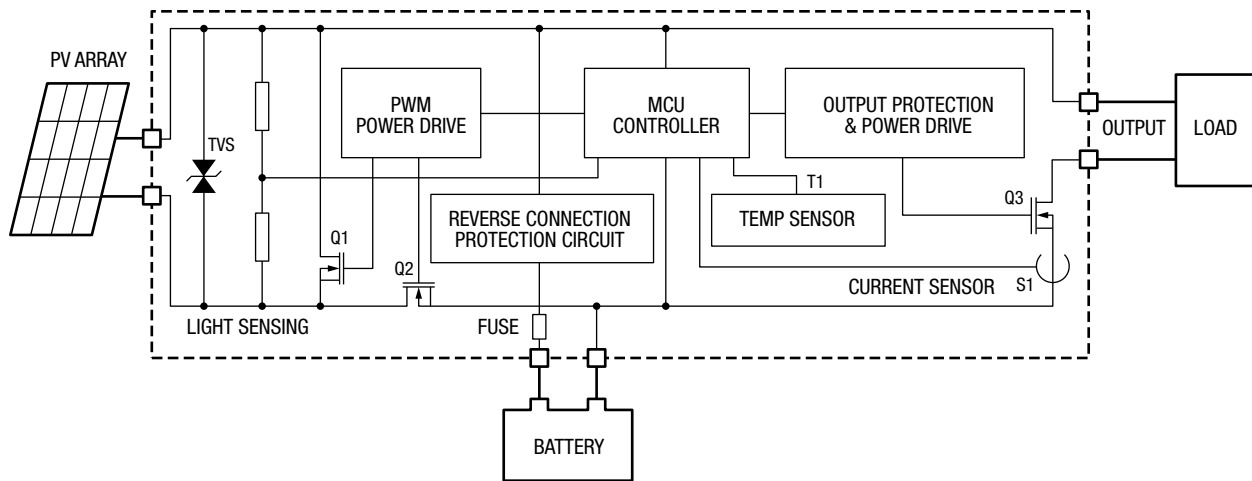

System diagram

Installation

Prior to installation:

- Check for shipping damage
- Check the contents to ensure correct model and powering options
- Make sure you have a suitable solar panel type and lead acid battery
- Have a clean, dry installation environment ready
- Observe safety precautions

Required for installation:

- Suitable wall or panel space for charge controller
- If used outdoors, the controller must be mounted inside a weatherproof cabinet or pedestal

Plan the installation of the battery pack and solar panel array prior to installation. For best results, mount the charge controller and batteries in a cabinet as close to the panels as practicable.

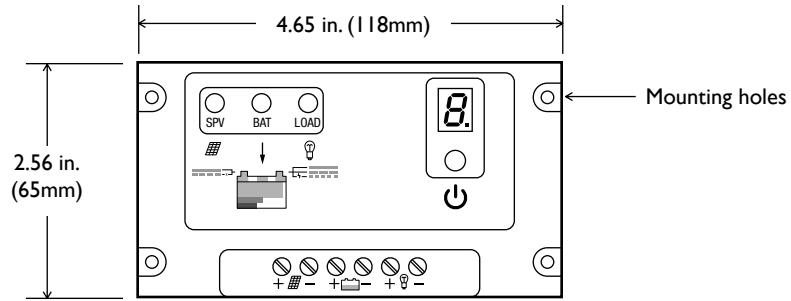

Mounting Dimensions

Connect Wiring

The screw-down terminals on the charge controller accept 12~26AWG wire. Strip the wire end approximately 0.2" (5mm) before connecting to the charge controller. Use caution when handling the stripped wires to avoid electric shock.

Step 1 - Connect the battery

Connect the battery wiring to the battery terminals on the charge controller. Note the polarity on the screw-down terminals. The charge controller self protection feature will prevent damage from reverse polarity connections, but the charge controller will not function until the battery is connected properly.

Step 2 - Connect the Solar Panel Array

Connect the wires from the solar panel array to the PV port on the charge controller. Note the polarity on the screw-down terminals. The charge controller self protection feature will prevent damage from reverse polarity connections, but the charge controller will not function until the solar panel array is connected properly.

Note: High voltages may be present on the solar panel output wiring. Solar panels produce electricity when exposed to light. Use caution and avoid touching any conductors in the system circuit to avoid electric shock.

Step 3 - Connect load

Connect the wires from the 48V industrial equipment to the load port on the charge controller. Note the polarity on the screw-down terminals. The charge controller self protection feature will prevent damage from reverse polarity connections, but the charge controller will not function until the load is connected properly. Press the Power/Mode button to turn on power to the load terminals.

Connection Diagram

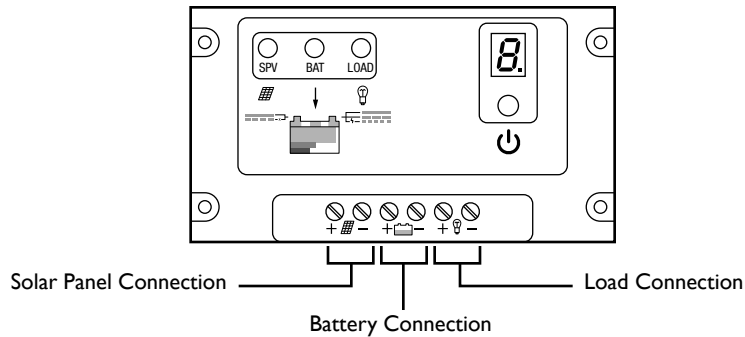

Operation

Once properly connected to a battery and solar panel array, the charge controller will immediately begin operating. When first connected, the Load LED will be off, indicating that the power to the load is off. Press the Power/Mode button to turn on power to the load.

Note: The solar power charge controller can only be used with lead acid type batteries.

LED Indicators

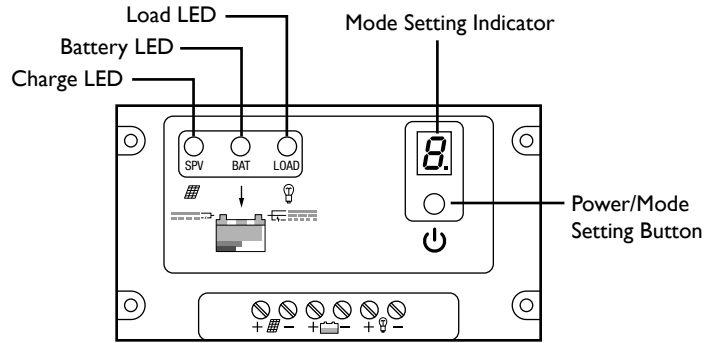

Charge LED

When the connected solar panel is exposed to sunlight, the Charge LED will be green, indicating that the system is charging normally.

The Charge LED will flash green when an overcharge condition or an open battery circuit exists.

PWM mode is used during charging. If an over-discharge of the battery has occurred, the charger will switch to boost voltage for 10 minutes, then will return to direct voltage for at least 10 minutes to activate the battery, and finally to the float voltage state where it will remain to maintain the best state of the battery. This multistep charging process will help bring the battery to full charge and maximize life span.

Battery LED

The Battery LED is green when the battery voltage is in normal condition. It will blink green slowly when the battery finishes its charge.

The LED is yellow when the voltage of the battery is below normal.

When battery voltage goes down continuously into an over-discharge condition, the Battery LED will turn red and the Load output will switch off.

The system will automatically resume normal operation and switch on the load output and when the battery voltage recovers to the over-discharge return voltage.

Load LED

The load LED is red when a load output is operating normally.

If the load current is 1.25 times higher than the rated current of the controller for 60 seconds, or 1.5 times higher than the rated current for 5 seconds, then the controller will shut down the output and the Load LED will blink red slowly to indicate that an overload condition occurred.

To resume normal operation, disconnect the load at fault and press the Power/Mode button. The charge controller will resume normal operation after 30 seconds.

The Load LED will blink red rapidly to indicate that a short circuit condition occurred. If a load short circuit occurs, the controller will shut down the output. If this happens, verify load connections. To resume normal operation, remove the short circuit at the load and press the Power/Mode button. The charge controller will resume normal operation after 30 seconds.

Setting Modes

The charge controller has a mode setting function to set specific operation parameters. It is preset to the factory default of normal control. The load will draw from the battery at all times, and the PV panel will charge the battery when sunlight is available.

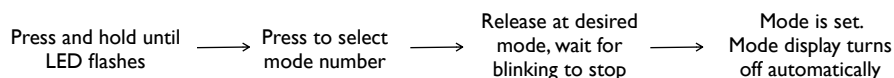

To set modes, press and hold the Power/Mode Button until the number on the LED display begins to flash. Press the button repeatedly to choose the desired mode number. When the desired number is selected, stop pressing the button and wait for number to stop flashing, indicating that the setting is completed. The display will turn off after several seconds. Press the button to check the value.

Note: Settings 10 through 17 have a dot (.) after the mode number.

Normal Control

This is the default setting. The load will draw from the battery at all times, and the PV panel will charge the battery when sunlight is available. When selecting this mode (6-dot), press the Power/Mode again after the mode is set to turn on the load output.

Note: In this mode only, the Power/Mode button will turn the load output on and off when pressed. After selecting this mode, make sure the load LED is on, indicating load output.

Night ON+ Day OFF control mode

The load will start working when it gets dark until it gets light. There is a 10 minute delay before turning on the load in order to make sure it is really dark and not a passing cloud etc.

Night ON + set time delay OFF mode

The load will switch on same as above, and remain on for a set duration. Once the selected time has elapsed, the load will switch off. The duration setting is listed in mode setting table. 1 to 15 hour delays can be selected, in increments of 1 hour. If the time setting overlaps with the occurrence of light control, then light control takes priority.

Common controller mode

The controller will work as a common controller, without light and time control, and no ON and OFF delay time. The load turns on immediately when there is no light, and off immediately when light is present on the PV panel.

Test mode

This is used for the testing the system by directly turning on the load output.

Mode	LED	Mode	LED	Mode	LED
Night ON + Day OFF	0	Night ON + 6 Hours delay OFF	6	Night ON + 12 Hours delay OFF	12
Night ON + 1 Hour delay OFF	1	Night ON + 7 Hours delay OFF	7	Night ON + 13 Hours delay OFF	13
Night ON + 2 Hours delay OFF	2	Night ON + 8 Hours delay OFF	8	Night ON + 14 Hours delay OFF	14
Night ON + 3 Hours delay OFF	3	Night ON + 9 Hours delay OFF	9	Night ON + 15 Hours delay OFF	15
Night ON + 4 Hours delay OFF	4	Night ON + 10 Hours delay OFF	10	Normal Control	6
Night ON + 5 Hours delay OFF	5	Night ON + 11 Hours delay OFF	11	Test (no delay)	7

Mode setting table

Troubleshooting

Symptom	Corrective Action
The charge LED indicator doesn't light green when the solar panel is exposed to sunlight.	Check if the solar panel cables are connected properly.
The charge LED indicator flashes rapidly.	System over voltage protection is working. Check for open circuit in battery, faulty battery connections to the system, or system charging circuit failure.
The load LED indicator is on but there is no power output.	Load open circuit. Check cables and connections and any other load switches.
The load LED indicator flashes red rapidly and there is no power output.	Check the output circuit for load short circuit or over load condition, remove the load and push the button and the controller will resume its work after 30 seconds.
The load LED indicator light flashes slowly and there is no power output.	An overload had occurred. Reduce or remove the load and push the Power/Mode button again. The controller will resume operation after 30 seconds.
System state LED indicator flashes red and there is no power output.	Over discharge of the battery. The controller will resume normal operation after the battery has finished charging.

Ordering Information

Part Number	Description
RLH-SCC-48-10	48V 10A Solar Charge Controller

- ▶ Please contact your RLH sales representative for pricing and delivery information.

Specifications

Rated charge current	10A
Rated load current	10A
Work voltage	48VDC
Over load, short circuit protection	1.25 rated load current 60sec, 1,5 rated loads current 5sec, over load protection action. ≥ 3 Rated load current short circuit protection action.
No load current	$\leq 6\text{mA}$
Charging circuit voltage drop	$\leq 0.26\text{V}$
Load circuit voltage drop	$\leq 0.15\text{V}$
Over voltage protection	68.0V
Operating temperature	$-35^{\circ}\text{C} \sim +50^{\circ}\text{C}$ ($-31^{\circ}\text{F} \sim +122^{\circ}\text{F}$)
Boost charge voltage	58.4V, Applied for 10mins. Only used for over-discharging.
Direct charge voltage	57.6V, Applied for 10mins.
Float charge voltage	54.4V
Charge return voltage	52.8V
Temperature compensation	$-5\text{mV}/^{\circ}\text{C}/2\text{V}$ (Boost charge, Direct charge, Float charge, charge return voltage)
Lower voltage indicate	48.0V
Over discharge voltage	44.4V (no load) - real-time modified voltage by the discharge rate.
Over discharge return voltage	50.4
Control mode	PWM charge mode; modified discharge voltage by the discharge rate

Specifications subject to change without notice

Warranty

RLH is recognized throughout the world and offers the only **UNCONDITIONAL LIFETIME WARRANTY** in the industry. We are very proud of our warranty which simply states that the product is warranted to be free of defects in material and workmanship for the **LIFE OF THE PRODUCT**.

RLH will replace this product, or part thereof, if it fails FOR ANY REASON, provided the defective part is returned to RLH Freight prepaid. This warranty is UNCONDITIONAL and valid even when this product has been abused, mishandled, or damaged as a result of a natural disaster. This warranty will reduce your costs and simplify your maintenance activities. Not all RLH products are covered by this warranty.

To make a warranty claim, or schedule repair or replacement of your RLH product, please contact us for an RMA number. You will be promptly assisted by one of our warranty specialists. All returns must have an RMA number before we can receive any items.

Technical Support

Normal technical support: (Mon - Fri 6am - 6pm PST)	Local (714) 532-1672 Toll Free (800) 877-1672 Toll Free (866) DO-FIBER
24/7 Technical support:	(714) 366-2503 (714) 396-8982 (714) 457-5740

Contact Information

Corporate Headquarters:	RLH Industries, Inc. 936 N. Main Street Orange, CA 92867 USA
Phone:	Local (714) 532-1672 Toll Free (800) 877-1672 Toll Free (866) DO-FIBER
Fax:	(714) 532-1885
Email:	info@fiberopticlink.com
Web site:	www.fiberopticlink.com

RLH FIBER OPTIC LINK

RLH Industries, Inc., The Leader in Fiber Optic Telecom Isolation Technology

LIFETIME

UNCONDITIONAL WARRANTY

RLH INDUSTRIES, INC. FIBER OPTIC LINK assemblies are warranted to be free of defects in materials and workmanship for the life of the product. This lifetime warranty is effective for RLH products sold from February 2, 1988, to the present, with the exception of fiber optic cable assemblies which are warranted only to be free of defects in manufacturing and batteries, which carry a 5-year unconditional replacement warranty.

RLH Industries, Inc. will repair or replace any product, or part thereof, that fails for any reason, provided the defective part is returned to RLH, freight prepaid.

This warranty is UNCONDITIONAL and is valid even when RLH Fiber Optic Link assemblies have been abused or mishandled, where unauthorized repairs have been attempted or performed, or product has been damaged as a result of a natural disaster.

Authorized by:



J. RANDALL MEARS, Vice President, Engineering



RLH Industries, Inc.
936 N. Main Street, Orange, CA 92867 USA
T: (714) 532-1672
F: (714) 532-1885

Please contact your RLH sales representative
for pricing and delivery information.

Specifications subject to change without notice.