

RLH 4RU Plug-in Fiber Card Housings with Optional Power Supply

NEBS LEVEL III CERTIFIED

Introduction

RLH 4RU Fiber Card Housings provide a mounting for RLH 4RU fiber card products in a NEBS certified enclosure. They are available in 5, 8, and 12 card capacities, and are 19/23" rack mountable, using 4 rack spaces (4RU). An internal DC power terminal and AC/DC switching 24/48V power supplies with UPS feature are available options.

These sturdy, powder coated, steel (standard color grey) housings come complete with wall and rack mounting hardware, fiber cable accessories and fiber slack brackets. The front access door is hinged and secures with thumb screw locks. The acrylic door panel allows for quick assessment of fiber optic card status and configurations. Multiple cable openings on the sides, bottom and back allow for flexible cable routing into and out of the housing.

The housings do not provide weather protection, and require a weatherproof enclosure for outdoor use. These NEBS Level III certified housings are covered by our Exclusive Unconditional Lifetime Warranty

Installation

Prior to installation:

- Check for shipping damage
- Check the contents to ensure correct model and power options
- Have a clean, dry, rack or wall installation environment ready

The fiber storage spools may need to be removed from the 12 card model for rack installation. Ensure that the housing is firmly mounted prior to installing 4RU fiber cards or attaching fiber cables. The front door is secured by the two thumbscrews at the upper corners.



5, 8 and 12 fiber card 4RU NEBS Level III housings

Standard Features

Exclusive Unconditional Lifetime Warranty

NEBS Level III certified

Optional plug-in 24 or 48VDC switching power supply and DC power terminal available

Power terminals accept one or two 24~56VDC inputs, and includes up to 12 outputs

Alarm contacts for power supply failure

Backup battery packs available for uninterruptible power operation

EIA 19/23" Rack or wall mount

Available in 5, 8, or 12 card capacities

Durable powder coated welded steel construction

Includes fiber management spools for fiber storage

Holds up to 12 4RU fiber cards in any configuration

Fiber management clamps and hardware included

19/23" Rack and wall mount hardware included

Specifications subject to change without notice.

Rack mounting

Install the mounting brackets with the mounting ears at the front for standard equipment racks, or half way back for telco style rack mounting. If required, attach the supplied 23" adapter plates to the mounting brackets before installing into the rack. Rack mount hardware is included with the housing. Cables may be routed through access grommets on the sides, back and bottom of the housing.



12 card housing with 19" rack mounting brackets

Wall Mounting

Install the mounting brackets with the mounting ears flush with the back of the housing. For wall mounting to wood backboard, use the included screws and flat washers. For all other mounting surfaces, use appropriate mounting hardware as required.

When installing, choose a location protected from the elements, and make sure there is sufficient room for the front door to open fully. Consider access to AC power, fiber cables, backup batteries and any other connections as required when installing.

DC power terminal option

Housings may be ordered with a power terminal connection. The power terminal provides DC distribution terminals for ease of wiring up individual fiber link cards and a dedicated connector for a UPS backup power source.

It accepts one or one or two 24-56VDC inputs. The second input can be used for a dual redundant powering arrangement for added reliability. The DC power terminal provides 6 or 12 outputs depending on the shelf size. Green LEDs indicate which terminal has power. A UPS terminal is also provided for connection to a battery backup for a complete UPS system.

The multiple outputs provide simple and convenient power wiring to each individual 4RU Fiber Optic Link card. This option is available with all housings by adding a "DC" to the end of the housing part number.

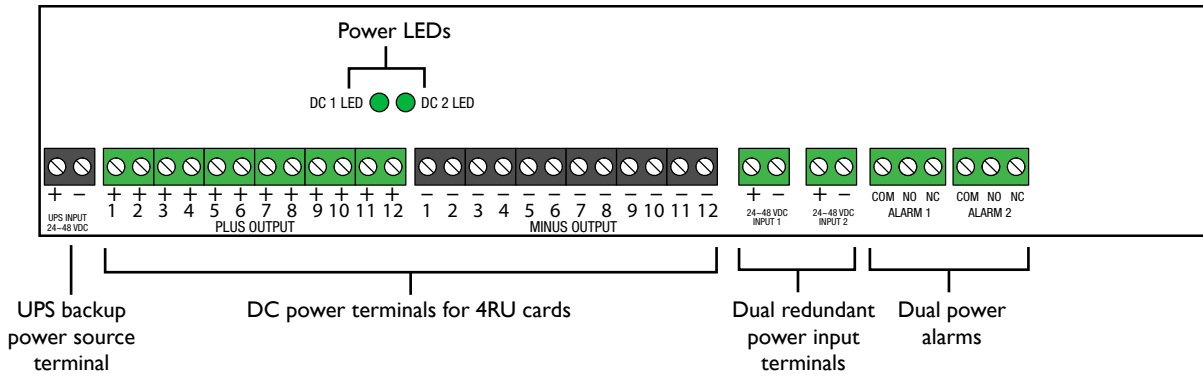

12-Position DC Power Terminal
6-Position DC Power Terminal is similar

Power supplies are connected directly to the terminal strip. Two power supplies may be used at the same time, providing redundancy. The power strip will automatically switch between the 2 inputs if a power supply fails, preventing an interruption in power.

The DC power terminal has 2 alarm contacts that provide alarms for incoming DC power to the terminal card. These alarm contacts are ideal for monitoring internal power supplies. However, the alarm contacts on the terminal strip will not indicate that a power failure has occurred if there is backup power applied to the UPS input. Refer to the section on using UPS backup power for additional information.

The connection diagram below shows a typical redundant power connection.

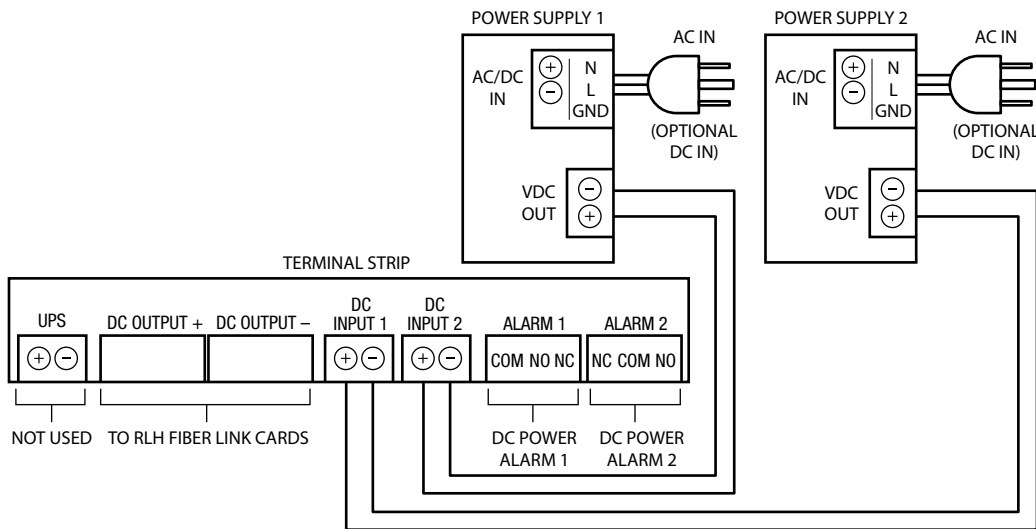

Power Terminal Connection Diagram

Using a UPS connection

When using a backup power source, such as the RLH 24V or 48V Battery Charge Controller with Backup Battery, use the alarm contacts on the charge controller itself to indicate when mains power or a power supply failure has occurred. If mains power supply is removed from the power strip, the charge controller alarm will indicate that the terminal strip and attached fiber link cards are operating off of backup battery power. Additionally, the RLH charge controller can relay battery and charge controller operation.

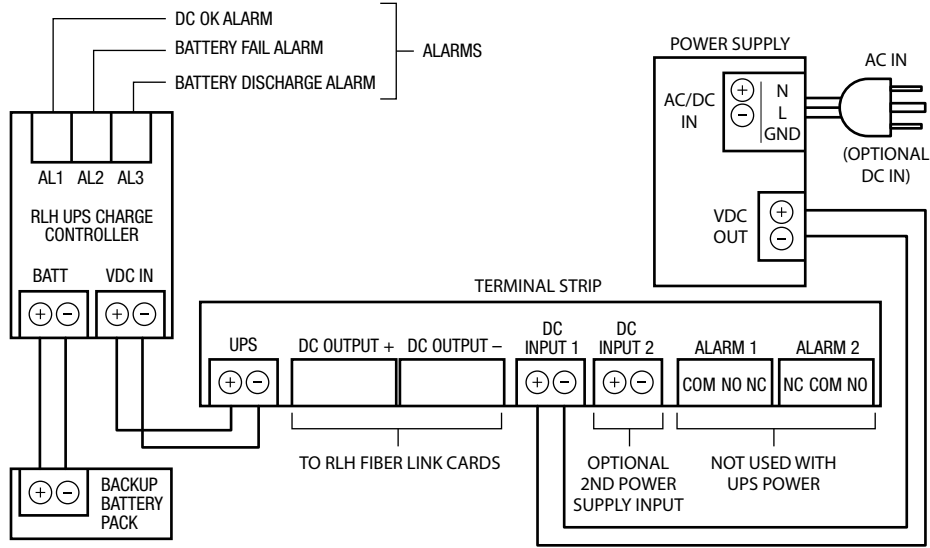

UPS Power Alarm Connection Diagram

AC/DC power supply option

Housings may be ordered with a switching power supply module preinstalled that converts AC or DC power. The power supply module occupies the last card position in the shelf. RLH AC/DC modules are available in both 24V and 48V output configurations, and a DC power terminal is preinstalled and prewired with the power supply.

For AC operation, plug the 6 ft. AC power cord into a standard 110V AC receptacle to apply power to the power supply.

For DC operation, remove the AC power cord and attach DC wiring. The DC inputs are polarity sensitive, so test the polarity of the DC input wiring before connecting to prevent damage to the power supply.

Connect the +DC lead to the AC L terminal, and the -DC lead to the AC N terminal.

Note: The DC power outputs are live when AC or DC input power is present.

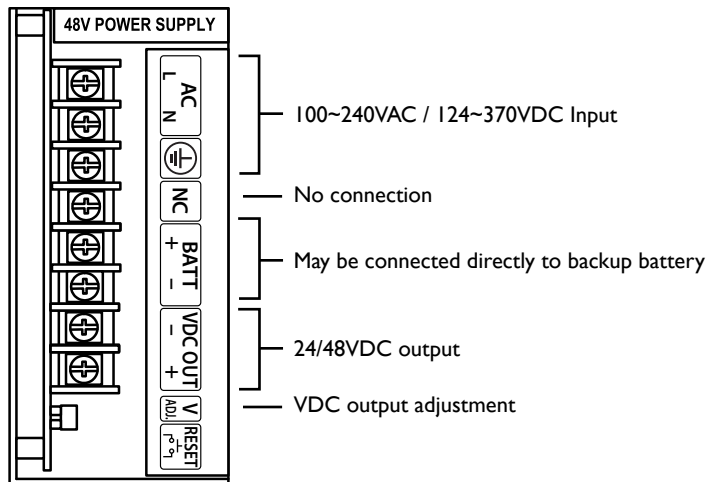

Power Supply Module

Backup battery connection

Power modules may be used with an external battery pack to provide temporary power in case of an AC outage. The power supply module will maintain the correct charge on the battery pack and automatically switch to battery power when needed. Battery packs are available separately in 24VDC and 48VDC configurations. Refer to the ordering information for compatible battery packs.

Connect the battery pack to the “B+” and “B-” terminals on the power module. Power supply modules may be ordered with housings by adding either an “A24” or “A48” to the end of the housing part number.

Refer to RLH’s full line of UPS systems, battery packs and charge controllers for backup power solutions.

Dimensions

(Rack/wall brackets and adapters not shown)

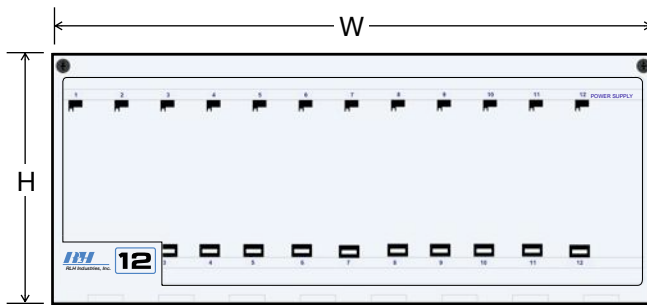

12 Card Housing

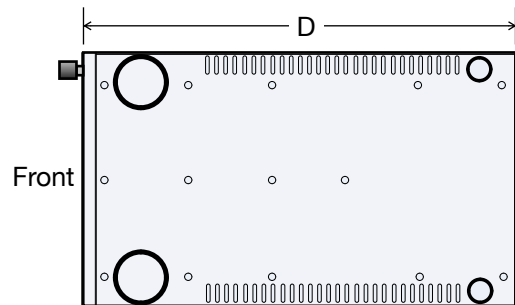

Housing side view, all models

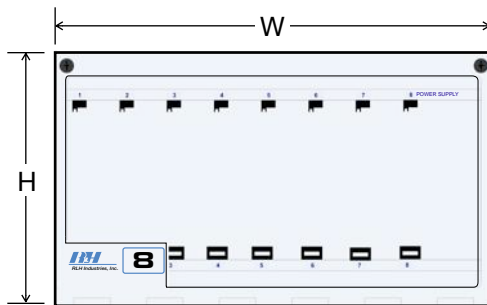

8 Card Housing

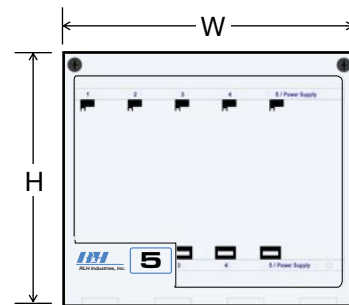

5 Card Housing

Capacity	Rack Space	HxWxD Dimensions (without mounting brackets)
5	4RU	H 7in. x W 8in. x D 11.5in. (178mm x 203mm x 292mm)
8	4RU	H 7in. x W 12in. x D 11.5in. (178mm x 305mm x 292mm)
12	4RU	H 7in. x W 17in. x D 11.5in. (178mm x 626mm x 292mm)

AC/DC power module specifications

		A24	A48
Input	Voltage Range	100-240VAC / 124-370VDC	
	Current	2.5A/115VAC	1.5A/230VAC
Output	DC Voltage	27.6VDC, 5A	54VDC, 2.7A
	Voltage Adj. Range	24 ~ 29V	48 ~ 58V
	Battery Charge Current	0.5A	0.2A
LED Indicators	DC output: Green		
Protection	Overload	105 ~ 135%	
	Type	AC Charging Mode : Constant current limiting, recovers automatically after fault condition is removed. UPS Mode : Protected by internal fuse	
	Overvoltage	31.74 ~ 37.26V	62.1 ~ 72.9V
		Protection type : Shut down o/p voltage, re-power on to recover	
	Battery Low	19.5V(+1.5V,-1V)	39V 2V
Environment	Working Temp.	-10°C ~ +60°C (14°F ~ 140°C)	
	Working Humidity	20~95% RH	
Safety & EMC	Standards	UL60950-1, TUV EN60950-1 approved	
	Withstand Voltage	I/P-O/P:3KVAC I/P-FG:1.5KVAC O/P-FG:0.5KVAC	
	Isolation Resistance	I/P-O/P, I/P-FG, O/P-FG:100M Ohms / 500VDC / 25°C / 70% RH	
	EMI Conductance & Radiation	Compliance to EN55022 (CISPR22) Class B	
	Harmonic Current	Compliance to EN61000-3-2,-3	
	EMS Immunity	Compliance to EN61000-4-2,3,4,5,6,8,11; ENV50204, EN55024, light industry level, criteria A	
Other	MTBF	183.3K hrs min. MIL-HDBK-217F (25°C)	
	Dimension	199 x 110 x 50mm (L x W x H)	
	Mounting	Factory installed with securing screw, occupies the last card slot.	

Specifications subject to change without notice.

Ordering Information

Part Number	Description
8806-1231-03	5 card 4RU housing
8806-1229-03	8 card 4RU housing
8806-1230-03	12 card 4RU housing

- ▶ Add **-DC** to end of part number for DC power terminal.
- ▶ Add **-A24** to end of part number for for 24V AC/DC power supply with DC power terminal.
- ▶ Add **-A48** to end of part number for for 48V AC/DC power supply with DC power terminal.
- ▶ Please contact your RLH sales representative for pricing and delivery information.

Replacement Power Supply Modules

Part Number	Description
RLH-ACPM-24	4RU Plug-in AC/DC Replacement Power Supply Module, 24VDC, 5A
RLH-ACMP-48	4RU Plug-in AC/DC Replacement Power Supply Module, 48VDC, 2.7A

Power Supply Module Compatible Battery Packs

System Voltage	Part Number	Capacity	Mounting	Dimensions
24V	8806-1205-02BP	1.2Ah	DIN/Wall Mount Battery Pack	H5.7" x W2.6" x D4.1"
	8806-1205-01BP	4.5Ah	DIN/Wall Mount Battery Pack	H4.75" x W9.5" x D4"
	8806-1206-03BP	7Ah*	Wall Mount Battery Pack	H8" x W8" x D4"
48V	8806-1204-01BP	1.2Ah	Wall Mount Battery Pack	H4.75" x W9.5" x D4"
	8806-1419-01BP	4.5Ah	Wall Mount Battery Pack	H11" x W9" x D6"
	8806-1214-01BP	7Ah*	Wall Mount Battery Pack	H11" x W9" x D6"

- ▶ Battery Packs include mounting hardware and fuse protection.
- ▶ Batteries are field replaceable.
- ▶ Contact RLH for replacement batteries.

Replacement Power Terminals

Part Number	Description
8806-1131-03	8-Position Power Terminal (24-56VDC) - Fits 5 and 8 Card Housing
8806-1130-03	12-Position Power Terminal (24-56VDC) - Fits 12 Card Housing

Technical Support

Normal technical support: (Mon - Fri 6am - 6pm PST)	Local (714) 532-1672 Toll Free (800) 877-1672 Toll Free (866) DO-FIBER
24/7 Technical support:	(714) 366-2503 (714) 396-8982 (714) 457-5740

Contact Information

Corporate Headquarters:	RLH Industries, Inc. 936 N. Main Street Orange, CA 92867 USA
Phone:	Local (714) 532-1672 Toll Free (800) 877-1672 Toll Free (866) DO-FIBER
Fax:	(714) 532-1885
Email:	info@fiberopticlink.com
Web site:	www.fiberopticlink.com

Warranty

RLH is recognized throughout the U.S. and offers the only **UNCONDITIONAL LIFETIME WARRANTY** in the telecommunications industry. We are very proud of our warranty which simply states that our Fiber Optic Link Assemblies are warranted to be free of defects in material and workmanship for the **LIFE OF THE PRODUCT**.

We can offer this warranty because:

- We believe our customers shouldn't have to incur additional costs due to failure or damage
- We engineer and manufacture our Fiber Optic Links in the USA, with total confidence in our quality
- We understand how safety and reliability impact the total cost of ownership
- We know that customer support extends beyond the initial sale, so **we stand behind our products**

RLH will replace any product, or part thereof, that fails **FOR ANY REASON**, provided the defective part is returned to RLH Freight prepaid. This warranty is **UNCONDITIONAL** and valid even when RLH Fiber Optic Link Assemblies have been abused or mishandled, where unauthorized repairs have been attempted or performed, or product has been damaged as a result of a natural disaster. Compare this warranty to our competitors and see how our warranty will reduce your costs and simplify your maintenance activities.

To make a warranty claim, or schedule repair or replacement of your RLH product, please contact us for an RMA number. You will be promptly assisted by one of our warranty specialists. All returns must have an RMA number before we can receive any items.



RLH Industries, Inc.
936 N. Main Street, Orange, CA 92867 USA
T: (714) 532-1672
F: (714) 532-1885

Please contact your RLH sales representative for pricing and delivery information.

Specifications subject to change without notice.