



RLH Industries, Inc.

USER GUIDE

The leader in rugged fiber optic technology.

✓ Unconditional Lifetime Warranty

2010B-0924

Ethernet Over Fiber Converter

1+1 PORT SLIMLINE DIN MOUNT

10/100M

Introduction

The RLH 1+1 Port SlimLine Ethernet Over Fiber system is a hardened, DIN mountable multifunction converter that supports 10/100M Ethernet communications over fiber optic cable. Fiber optics not only provide the long distance Ethernet transmission capability up to 74 miles (120km), but also provide immunity to EMI/RFI and transient surges. They are ideal for data communications near large electrical equipment or where radio interference can be an issue.

The SlimLine converter is a compact unit that requires only 32mm of DIN rail space, and requires a local 12~36VDC power to operate.

Key Features

- Ideal for critical, high voltage, remote or un-manned locations that must remain operating 24/7/365
- IEEE 802.3, IEEE 802.3x, IEEE 802.3u compliant
- RJ45 UTP port with 10/100 auto-negotiation
- MDI-II/MDI-X auto detection
- Extends network span up to 1.2 miles (2km) on multimode and up to 74 miles (120km) on single-mode fiber
- Convenient LED status indicators
- Dual and Single (bi-directional) fiber models available
- Environmentally hardened to operate in -40°F to +185°F (-40°C to +85°C) environments
- DIN rail mount
- Covered by our Exclusive Unconditional Lifetime Warranty



RLH Ethernet over fiber converter with DIN rail mount

ETHERNET OVER FIBER

Contents

Introduction	1
General Safety Practices	2
Special Handling Requirements	2
Acronyms	3
Applications	4
Installation	4
LED Indicators	5
Troubleshooting	6
Ordering Information	6
Specifications	7
Warranty	8
Technical Support	8

Specifications subject to change without notice.

General Safety Practices

Intended Audience

This guide is intended for use by knowledgeable telco/network installation, operation and repair personnel. Every effort has been made to ensure the accuracy of the information in this guide is accurate. However, due to constant product improvement, specifications and information contained in this document are subject to change without notice.

Conventions

Symbols for notes, attention, and caution are used throughout this manual to provide readers with additional information, advice when special attention is needed, and caution to prevent injury or equipment damage.

The equipment discussed in this document may require tools designed for the purpose being described. RLH recommends that service personnel be familiar with the correct handling and use of any installation equipment used, and follow all safety precautions including the use of protective personal equipment as required.

Caution - Severe Shock Hazard

- Never install during a lightning storm or where unsafe high voltages are present.
- Copper network wires may carry high DC voltages. Use caution when handling copper wiring.

Warning

The intra-building port(s) of the equipment or subassembly is suitable for connection to intrabuilding or unexposed wiring or cabling only. The intra-building port(s) of the equipment **MUST NOT** be metallically connected to interfaces that connect to the OSP or its wiring. These interfaces are designed for use as intra-building interfaces only (Type 4 ports as described in GR-1089-CORE, Issue 4) and require isolation from the exposed OSP cabling. The addition of Primary Protectors is not sufficient protection in order to connect these interfaces metallically to OSP wiring.

Special handling requirements

Be careful when handling electronic components

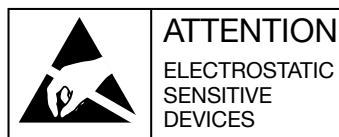

- This product contains static sensitive components.
- Do not open the enclosure, there are no user serviceable parts.
- Follow proper electrostatic discharge procedures.

This product utilizes circuitry that can be damaged by static electricity. Before installing, discharge static electricity on your body by physically making contact with earth ground. Failure to follow ESD precautions may cause damage to the unit and prevent proper operation.

Guidelines for handling terminated fiber cable

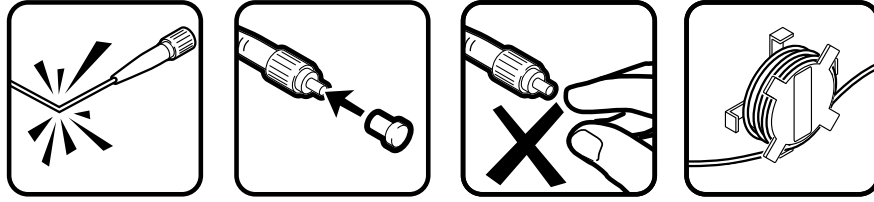

- Do not bend fiber cable sharply. Use gradual and smooth bends to avoid damaging glass fiber.
- Keep dust caps on fiber optic connectors at all times when disconnected.
- Do not remove dust caps from unused fiber.
- Keep fiber ends and fiber connectors clean and free from dust, dirt and debris. Contamination will cause signal loss.
- Do not touch fiber ends.
- Store excess fiber on housing spools or fiber spools at site

Acronyms

Commonly used acronyms and abbreviations

Acronym/Abbreviation	Description
UTP	Unshielded Twisted Pair (commonly used in Ethernet networks)
TP	Twisted Pair (same as UTP)
TX	Transmit
RX	Receive
PWR	Power
LED	Light Emitting Diode
GRN	Green
ORG	Orange

Applications

Network equipment in high voltage areas can be at risk due to Ground Potential Rise (GPR). A copper network cable referenced to a remote ground can become a path for high voltages during a ground fault. Use of all-dielectric fiber optic cable instead of copper completely eliminates the presence of a remote ground, which dramatically increases safety of personnel and reliability of equipment. By utilizing fiber optic cable, the 10/100/1000 Ethernet over fiber converter provides absolute electrical isolation between both ends of the network.

Copper twisted pair Ethernet is limited to 100m/328ft without extenders. Using fiber optic cable provides long distance service up to 120km/74mi. without any additional equipment. Optical fiber is immune to EMI/RF interference, ground loops, and high voltage surges from lightning or ground faults, and is ideal in electrically noisy environments such as near large power sources, electrical motors, and radio communications equipment.

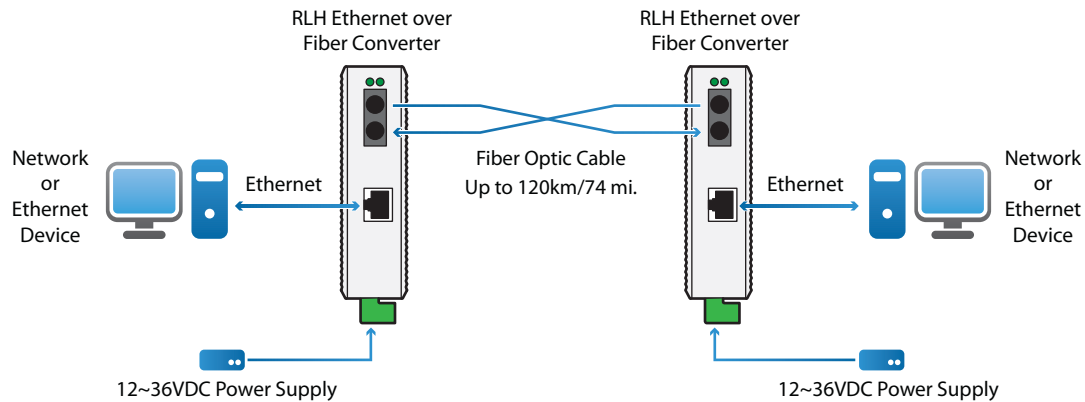

Typical Ethernet System Diagram

Installation

Prior to installation:

- Check for shipping damage
- Check the contents to ensure correct model and fiber type
- Have a clean, dry, DIN rail or wall mount installation environment ready

Required for installation:

- 12~36VDC local power source

Note: In order to maintain high voltage isolation, Units at each end must be powered from separate isolated power sources.

Connect fiber optic cable

Multimode and single-mode Ethernet cards are equipped with dual ST, SC or FC female optical connectors, or a single bi-directional connector, depending on the model.

Connect fibers to the TX (Transmit) and RX (Receive) optical connectors. For dual fiber models, the TX connector must go to the RX connector on the unit at the other end. The other end of the fiber may be connected to another SlimLine 10/100 Ethernet converter or any compatible 100Base-FX Fiber Optic Ethernet device.

For bi-directional, single fiber models, there is only one connector used for transmitting and receiving. Bi-directional units must be used in pairs.

Note: Fiber cable should always be routed loosely avoiding tight bends.

Connect Ethernet cable

The 10/100/Base-T copper connection is made via the RJ45 port. The TP port is auto-negotiating and requires no additional settings.

Connect Power

Attach a FG ground wire to the ground screw on the housing. Alternately, attach a ground wire to the FG terminal on the power connector. Connect a local 12~36VDC power supply to the power input terminals.

Note: The power terminals are polarity sensitive. Attach the Positive DC wire to the V+ terminal.

LED Indicators

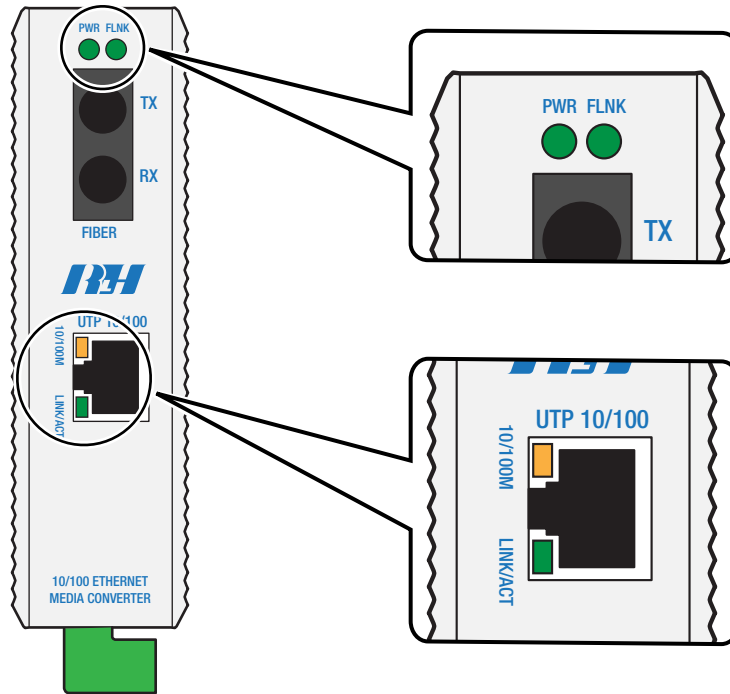

Indicator	Color	LED	Description
PWR	GRN	ON	System power is present
		OFF	System power is disconnected
FLNK	GRN	ON	Fiber link OK
		OFF	Fiber link FAIL
10/100M	ORG	ON	TP port speed is 100M
		OFF	TP port speed is 10M
		ON	Established network connection
LINK/ACT	GRN	Blinking	TP port activity
		ON	Established network connection
		OFF	No network connection established

Troubleshooting

If trouble is encountered, verify all copper and fiber connections. Refer to the LED Indicators on of the unit. They show availability of power, modes of operation, and data being received by the fiber and TP ports.

If trouble persists, replace the unit and retest. If technical assistance is required, contact the RLH Industries, inc. technical support department:

800-877-1672 (6 am to 6 pm- PST),
or call our 24/7 Technical/Customer Service: (714) 366-2503 or (714) 457-5740

Ordering Information

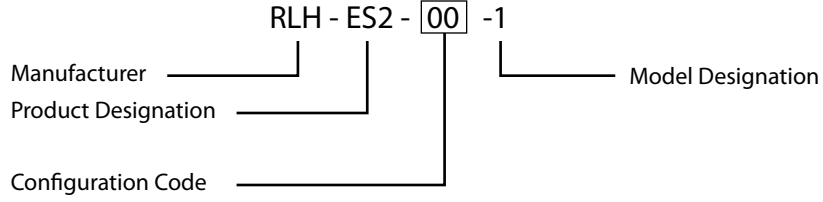

Code	Multimode	Single Mode	Single Fiber Bi-Directional	Dual Fiber	SC Connector	ST Connector	FC Connector	2km/1.25mi. range	20km/12.4 mi. range	40km/24.9 mi. range	60km/37 mi. range	120km/74 mi. range	FXO/CO Side	FXS/Sub Side	Either Side
01	●		●		●			●					●		
02	●		●		●			●						●	
03	●			●	●			●							●
04	●			●		●		●							●
05	●			●			●	●							●
10		●	●		●				●				●		
11		●	●		●				●					●	
12		●	●		●					●			●		
13		●	●		●					●				●	
14		●	●		●						●		●		
15		●	●		●						●			●	
20		●	●			●			●				●		
21		●	●			●			●					●	
22		●	●			●				●			●		
23		●	●			●				●				●	
24		●	●			●					●		●		
25		●	●			●					●			●	
30		●	●				●		●				●		
31		●	●				●		●					●	
32		●	●				●			●			●		
33		●	●				●			●				●	
34		●	●				●				●		●		
35		●	●				●				●			●	
40		●		●	●				●						●
41		●		●	●					●					●
42		●		●	●						●				●
50		●		●		●			●						●
51		●		●		●				●					●
52		●		●		●					●				●
60		●		●			●		●						●
61		●		●			●			●					●
62		●		●			●				●				●

- ▶ Bidirectional single fiber models require a TX unit and a RX unit for a complete system
- ▶ Please contact your RLH sales representative for pricing and delivery information

Specifications subject to change without notice.

General Specifications

Protocols	100Base-FX, 10Base-T, or 100Base-TX				
Standards	IEEE 802.3, IEEE 802.3x, IEEE 802.3u compliant				
Copper Connector	RJ45 UTP				
Copper Distance	100m / 328 feet				
Fiber Connector	ST, SC OR FC*				
	Dual fiber or single bidirectional fiber connectors				
Dual Fiber Optics	Fiber Type	Multimode		Single-mode	
	Wavelength TX/RX (nm)	1310	1310	1310	1310
	Distance	2km / 1.2 mi.	20km / 12 mi.	60km / 36 mi.	120km / 74 mi.
	Min. TX PWR (dBm)	-18	-15	-6	0
	Max. TX PWR (dBm)	-10	-8	-3	+5
	RX Sensitivity (dBm)	-31	-34	-34	-34
	Link Loss Budget (dBm)	13	19	28	34
	Single Fiber Optics (Bi-directional)	Fiber Type	Multimode		Single-mode
Wavelength (nm)		1550	1550	1550	1550
Distance		2km / 1.2 mi.	20km / 12 mi.	40km / 25 mi.	60km / 36 mi.
Min. TX PWR (dBm)		2-17	-14	-9	-5
Max. TX PWR (dBm)		-10	-8	-5	-3
RX Sensitivity (dBm)		-31	-34	-34	-34
Link Loss Budget (dBm)		14	20	25	29
LED Indicators		PWR	System power - ON: power OK, OFF: no power		
	FLNK	Fiber port link - ON: Link OK, OFF: link fail			
	10/100M	10/100 TP port speed - ON: 100M, OFF: 10M			
	LINK/ACT	TP link - ON: Connection is OK, Blink: Port Activity, OFF: No network connection present			
Power Input	12~36VDC, 0.5W, Screw-down terminal block				
Dimensions	H4.1" x W1.3" x D3.1" (103mm x 32mm x 78mm) not including DIN mount bracket				
Temperature	Operating	-40°F to +185°F (-40°C to +85°C)			
	Storage	-49°F to +185°F (-45°C to +85°C)			
Humidity	5~95% non-condensing				

* Multimode bidirectional sing fiber optics available with SC connectors only

Warranty

RLH is recognized throughout the U.S. and offers the only **UNCONDITIONAL LIFETIME WARRANTY** in the telecommunications industry. We are very proud of our warranty which simply states that our Fiber Optic Link Assemblies are warranted to be free of defects in material and workmanship for the **LIFE OF THE PRODUCT**.

RLH will replace this product, or part thereof, if it fails FOR ANY REASON, provided the defective part is returned to RLH Freight prepaid. This warranty is UNCONDITIONAL and valid even when this product has been abused, mishandled, or damaged as a result of a natural disaster. This warranty will reduce your costs and simplify your maintenance activities. Not all RLH products are covered by this warranty.

To make a warranty claim, or schedule repair or replacement of your RLH product, please contact us for an RMA number. You will be promptly assisted by one of our warranty specialists. All returns must have an RMA number before we can receive any items.

Technical Support

Normal technical support hours (Mon - Fri 6am - 6pm PST)	Local (714) 532-1672 Toll Free (800) 877-1672 Toll Free (866) DO-FIBER
24/7 Technical support	(714) 366-2503 (714) 457-5740

Contact Information

Corporate Headquarters	RLH Industries, Inc. 936 N. Main Street Orange, CA 92867 USA
Phone	Local (714) 532-1672 Toll Free (800) 877-1672 Toll Free (866) DO-FIBER
Fax	(714) 532-1885
Email	info@fiberopticlink.com
Web site	www.fiberopticlink.com



RLH Industries, Inc.
936 N. Main Street, Orange, CA 92867 USA
T: (714) 532-1672
F: (714) 532-1885

Please contact your RLH sales representative for pricing and delivery information.

Specifications subject to change without notice.