



RLH Industries, Inc.

## PRODUCT INFORMATION

The leader in  
rugged fiber optic  
technology.

✓ Unconditional  
Lifetime Warranty

2010B-1221

# Wall Mount 19" Rack Bracket

EIA 19" 1RU AND 2RU EQUIPMENT RACKS

## Description

The RLH Wall Mount 19" 2RU Rack bracket simplifies the mounting of 19" rack equipment to a wall or panel surface. Constructed of heavy duty stainless steel, this 2RU (2 Rack Unit) bracket features slotted mounting holes and a hinged rack ear that allows the user to gain access to the rear of mounted equipment without having to completely remove it from the rack.

Rack mount and wall mount hardware is included. Part number information is listed on page 2.

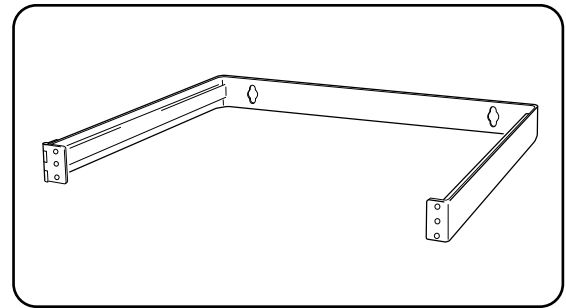

RLH Wall Mount 19" 1RU Rack Mount Bracket

### Key Features

- Ideal for mounting patch panels, switches, hubs and other 19" rack mount network equipment.
- Hinged rack ear for easy access
- Heavy duty welded stainless steel construction
- Mounting hardware included
- Covered by our Exclusive Unconditional Lifetime Warranty

### 1 RU Wall Mount Rack Bracket

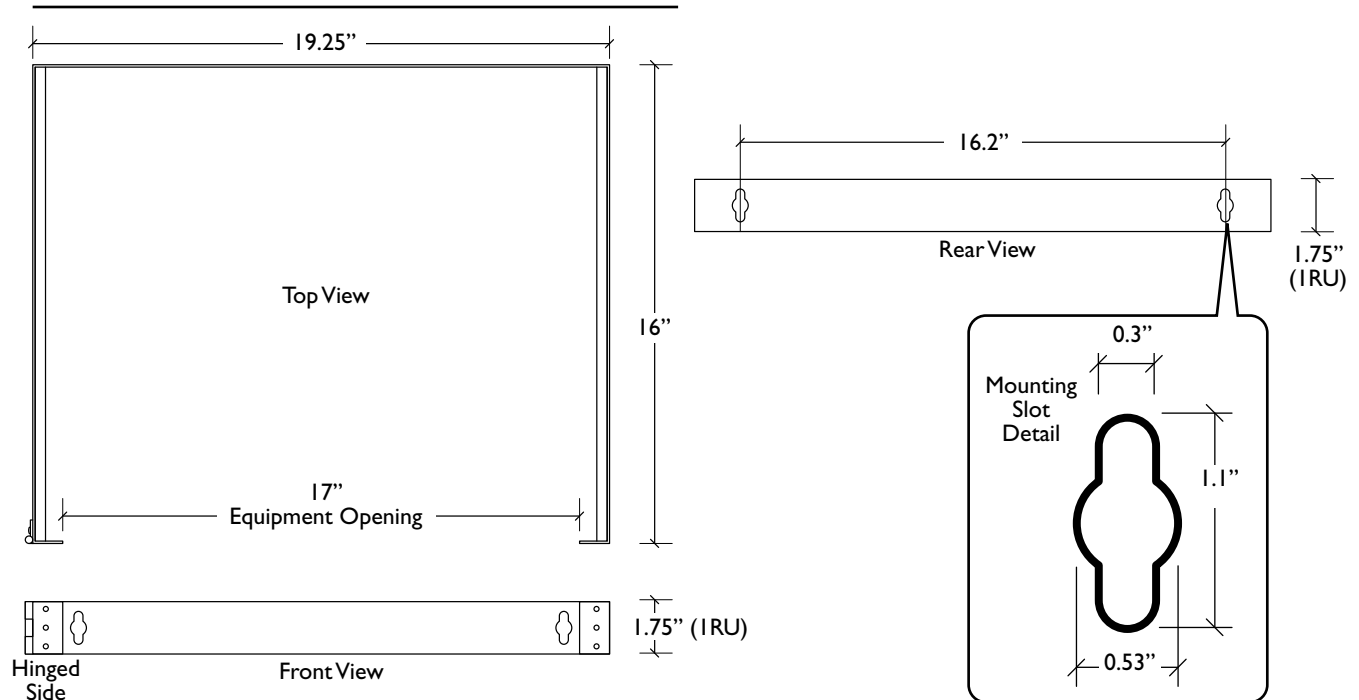

Specifications subject to change without notice.

**2 RU Wall Mount Rack Bracket**

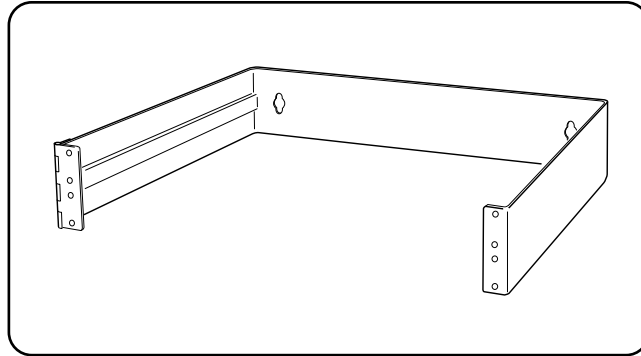

RLH Wall Mount 19" 2RU Rack Mount Bracket

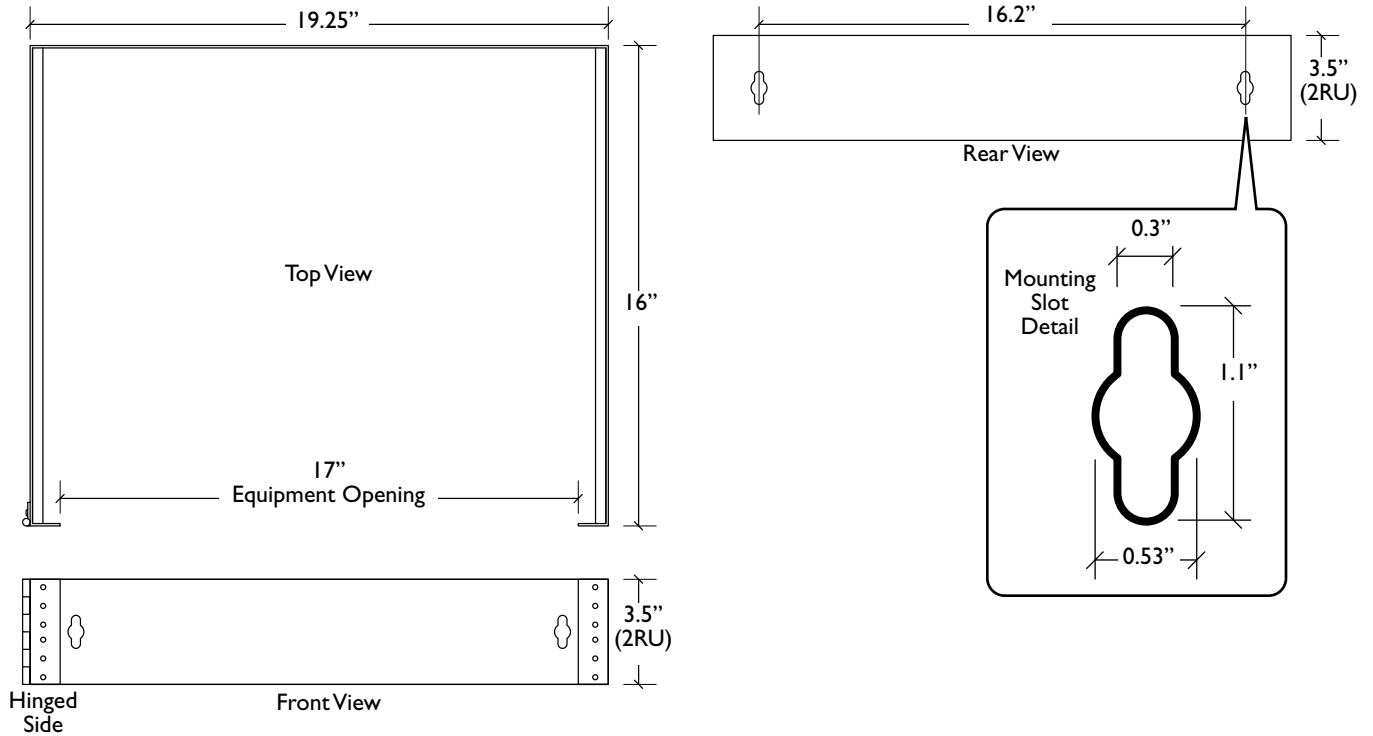

**Ordering Information**

Part No.	Description
WRB1-01	1RU wall mount 19" rack bracket
WRB2-01	2RU wall mount 19" rack bracket

▶ Please contact your RLH sales representative for pricing and delivery information

Specifications subject to change without notice.