

Single Channel T-1 Interface Fiber Optic Link System

Specifications and Application Information



Description

The Fiber Optic Link T-1 Model 2 (backwards compatible with the Model 1) System processes incoming bipolar signals (7.2 V P-P Max) within a bandwidth of 100 KHz to 10 MHz T-1 (1.544Mbps) or (CCITT 2.048Mbps), optically transmits these signals via fiber optic cable and converts the signal to the original electrical signal with minimal gain or loss. Output to the copper line is automatically maintained at a nominal level. The Fiber Optic Link system is compatible with European E1. Transient voltages appearing on or between the 4-wire pairs and/or power supply input are limited by thermistors, gas tubes and MOVs.

T-1 CO Side Card

The T-1 CO Card provides the interface between a Telco Central Office T-1 copper 4-wire line and a two strand fiber optic cable. It may also be used to extend a Telco demarcation point over fiber with the capability to be line power by a 60mA simplex/loop current. See page 4 for further details.

T-1 Sub Side Card

The T-1 Sub Card provides the interface between the Subscriber equipment copper 4-wire line and a two strand fiber optic cable.

Contents

Description	1
General Safety Practices	3
Special Handling Requirements	3
Application	4
LED Status Indicators	5
NIU Compatibility	6
Ordering Information	6
Specifications	7
Warranty	8
Technical Support	8

Compliance Information

The RLH T-1 Fiber Optic Link System is compliant with the following industry standards:

- **NEBS Level 3**
- **FCC PART-15**
- **FCC PART-68B**
- **IEEE-80 IEEE-367**
- **IEEE-487**
- **IEEE-1590**
- **IEEE-1615**
- **Motorola R56**
- **BR 876-310-100 BT (Telcordia)**
- **Bellcore SR-3966**
- **GR-1089**
- **GR-63**

Specifications subject to change without notice.

Typical T1 application environments

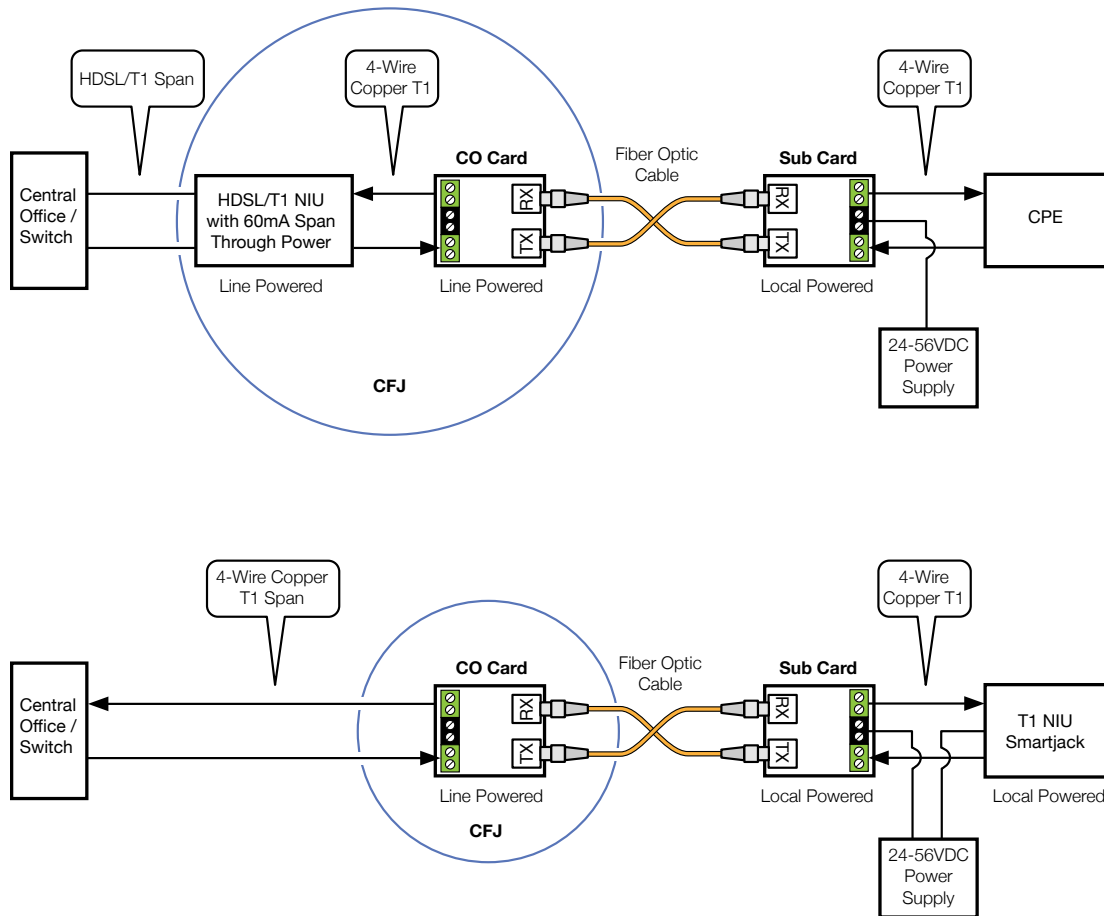

T1 System Diagram

CO card powering

The T1 CO card is typically powered by 60mA Telco simplex current on the T1 transmit and receive pairs. The card may also be powered by an **isolated** 24-56VDC source. The card is polarity insensitive to all electrical connections.

Sub Card Powering

The Sub card is typically powered by a 24-56VDC source. Alternately the card can be powered via 60mA simplex onto the T-1 Send and Receive pairs by the Subscriber Equipment. The T-1 Card is polarity insensitive to all electrical connections. The power supply on the T-1 Card limits current at 64mA.

Note: In order to maintain high voltage isolation, Fiber Optic Link CO and Sub cards must be powered from separate power sources.

General Safety Practices

The equipment discussed in this document may require tools designed for the purpose being described. RLH recommends that service personnel be familiar with the correct handling and use of any installation equipment used, and follow all safety precautions including the use of protective personal equipment as required.

Caution - Severe Shock Hazard

- Never install during a lightning storm or where unsafe high voltages are present.
- Active T1 lines carry high DC voltages up to 56V. Use caution when handling T1 wiring.
- Active UHDSL lines carry high DC voltages up to 210V. Use caution when handling UHDSL wiring.

Warning

The intra-building port(s) of the equipment or subassembly is suitable for connection to intrabuilding or unexposed wiring or cabling only. The intra-building port(s) of the equipment **MUST NOT** be metallically connected to interfaces that connect to the OSP or its wiring. These interfaces are designed for use as intra-building interfaces only (Type 4 ports as described in GR-1089-CORE, Issue 4) and require isolation from the exposed OSP cabling. The addition of Primary Protectors is not sufficient protection in order to connect these interfaces metallically to OSP wiring.

Refer to the Single Channel T-1 Fiber Optic Link System **Installation and Troubleshooting Guide** for comprehensive installation information.

Observe special handling requirements

Be careful when handling electronic components

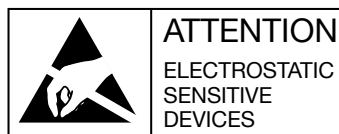

- This product contains static sensitive components.
- Handle the T1 cards at their edges only.
- Follow proper electrostatic discharge procedures.

This card utilizes circuitry that can be damaged by static electricity. When transporting the card, carry it in an ESD safe container such as the antistatic bag provided with the card. Before handling cards, discharge yourself of static electricity by physical bodily contact with earth ground. When handling cards, hold by outer edges and avoid touching circuitry. Failure to follow ESD precautions may cause serious damage to the card and prevent proper operation.

Guidelines for handling terminated fiber cable

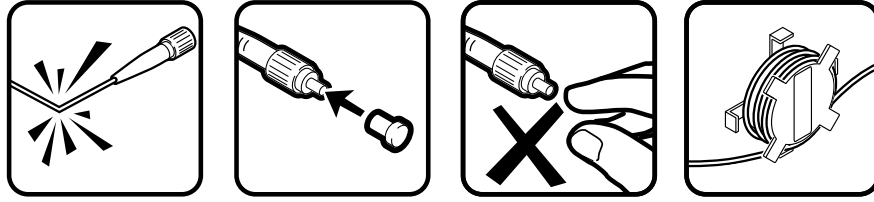

- Do not bend fiber cable sharply. Use gradual and smooth bends to avoid damaging glass fiber.
- Keep dust caps on fiber optic connectors at all times when disconnected.
- Do not remove dust caps from unused fiber.
- Keep fiber ends and fiber connectors clean and free from dust, dirt and debris. Contamination will cause signal loss.
- Do not touch fiber ends.
- Store excess fiber on housing spools or fiber spools at site

Application

Telecommunication equipment in high voltage areas can be at risk due to Ground Potential Rise (GPR). A copper telephone line referenced to a remote ground can become a path for high current during a ground fault. Placement of all-dielectric fiber optic cable (instead of copper wire) from outside the high voltage area eliminates the safety hazard to personnel and equipment by removing the telephone remote ground. Standard 3-element gas tube copper protection is recommended at the 300V point for proper installation.

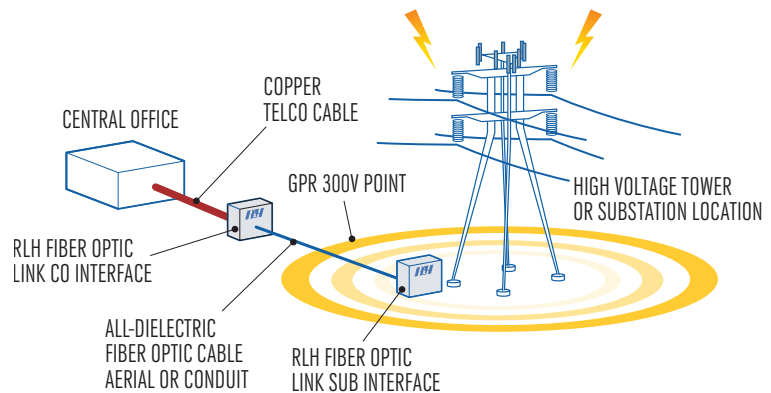

Note: In order to maintain high voltage isolation, Fiber Optic Link CO and Sub cards must be powered from separate isolated power sources.

Line Powering

When an HDSL or T1 NIU is placed at the CO side of the Fiber Optic Link it must provide span through line power to the T1 CO fiber interface card. The T1 CO card can be line powered via 60mA simplex current on the line. When line power is available no external or local power is required to operate the fiber card. An active T1 line with 60mA line power connected to the fiber interface card should measure 22-23VDC between transmit and receive pairs. If voltage is not present verify the NIU model number using the **NIU Compatibility Chart** listed in this document, or contact RLH to ensure span-through power capability.

LED status indicators

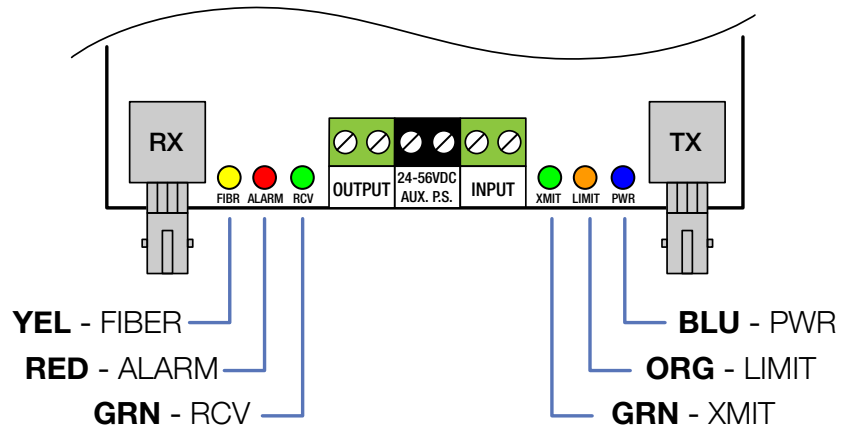

LED	Color	ON condition	OFF condition
FIBR (Fiber Test)	YEL	<ul style="list-style-type: none"> • “Fiber signal” switch SW2 is ON at the far end card. • Fiber test signal is being received. 	<ul style="list-style-type: none"> • Normal operation (“Fiber Signal” switch is OFF at the far end card) • If SW2 is ON on far end card, check fiber continuity
ALRM (Alarm)	RED	Signal is below minimum operating level	Normal operation
RCV (Receive)	GRN	Signal is received from fiber	Normal operation
XMIT (Transmit)	GRN	Signal is received at copper input	Normal operation
LIMIT	ORG	Copper input signal overload	Normal operation
PWR (Power)	BLU	DC power is connected	No DC power is connected

NIU Compatibility

Check for compatible NIU systems that supply Span Through-Power to the T-1 Fiber Optic Link cards.
Contact RLH for T-1 compatibility with systems not listed.

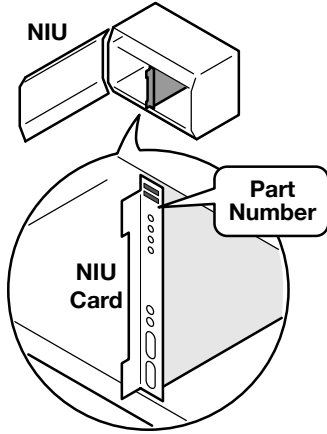

HDSL/T1 Span Through Power NIU Compatibility Chart			
Manufacturer	Part Number	Description and Material ID	CLEI Code
HDSL1			
Adtran	1246026L4	T200 HTU-R (VZ# 594993)	T1L2C8J8AA
Adtran	1246026L5	T200 HTU-R (BST# 98001580)	T1L3KD5AAA
Adtran	1245024L1	T400 HTU-R	T1L2C8J8AA
Adtran	1247026L1	T200 HTU-R,	
ADC	SPX-HLXRD11	T400 HLXR	SND1FJRAAA
HDSL2			
Adtran	1223024L1	H2TU-R (VZ# 11018736)	T1L6VR8B_ _
HDSL4			
Adtran	1223424L1	H4TU-R (VZ# 11018731)	T1L6EYHB_ _
Repeated T1			
Adtran	1181315L1-5B	T1 NIU, Total Access	T1L3PU0A
Hyperedge	520-10-SWI3	T200 T1 NIU (BST# 300058336)	
Westell	DNI5760LNI3	T1 NIU (VZ# NCIUV9A)	NCIUV9A4AA
Westell	A90-3128-70	T1 NIU (VZ# T1L3P96)	T1L3P96CAA
Westell	A90-3115-31	T1 NIU (VZ# T1S1AEF)	T1S1AEFAAA

Ordering Information

Fiber Type	Connector Style	4 Wire T1/EI CO Card	4 Wire T1/EI Sub Card
Multimode	ST	8806-1315-02	8806-1325-02
Multimode	SC	8805-1315-02	8805-1325-02
Single-mode	ST	8806-1300-02	8806-1310-02
Single-mode	SC	8805-1300-02	8805-1310-02
Single-mode (Long Haul)	ST	8806-1300-02LH	8806-1310-02LH
Single-mode (Long Haul)	SC	8805-1300-02LH	8805-1310-02LH

* Note: Add -RJ to part number to include RJ adapter with the card

Part Number	Description
RLH-RJTI-CO	RJ-48C Adapter for CO 4Wire T1 Card
RLH-RJTI-SUB	RJ-48C Adapter for SUB 4Wire T1 Card

► Please contact your RLH sales representative for pricing and delivery information.

General Specifications

The Fiber Optic Link T-1 Model 2 (backwards compatible with the Model 1) System processes incoming bipolar signals (7.2 V P-P Max) within a bandwidth of 100 KHz to 10 MHz T-1 (1.544Mbps) or (CCITT 2.048Mbps). It optically transmits these signals via fiber optic cable and converts the signal to the original electrical signal.

Output to the copper line is automatically maintained at a nominal level. The Fiber Optic Link system is compatible with European E1.

Standard specifications

Transmission method	Amplitude modulated light via two optical fibers
	Multimode: 850nm (Tx level: -16dB +/- 1dB)
	Single-mode: 1310nm (Tx level: -23dB +/- 1dB)
	Single-mode Long Haul: 1310nm (Tx level: -6dB +/- 2dB)
Maximum Fiber Attenuation / Distance	Multimode: 10dB / 1.5 miles (2.5 km)
	Single-mode: 8dB / 9 miles (15 km)
	Single-mode Long Haul: 26dB / 37 mi. (60 km), Required min. loss 8dB
	*Note: Distances equated using industry standard fiber and connector attenuation of 3dB/Km. Fiber condition, splices and connectors may affect actual range.
Fiber Type	(ST or SC connectors) Multimode: 62.5/125µm, 50/125µm
	Single-mode: 8-9/125µm
Temperature Limits	-40°F to +158°F (-40°C to +70°C)
Humidity	95% non-condensing
Bandwidth	100 kHz to 10 MHz
Signal to Noise	>45 dB for line attenuation up to 30 dB at 772 kHz
Digital Data Type	Bipolar digital data stream with no DC reference
Maximum Data Rate	3.152 Mbps
BER	<10 ⁻⁹
Transmit Level (Loss Select at position 1)	6V P-P Nominal at 20°C (68°F) 4.8V P-P to 6.5V P-P from -40°C to 70°C (-40°F to +158°F)
Surge Protection	Fuses, thyristors, PTC thermistors, zeners, and MOVs
Power Requirements	CO/ Sub Cards: 24-56 VDC, 57-66mA
Powering Method	Line power simplex on Send and Receive pairs, or an isolated DC power source connected to AUX. P.S. input.

Warranty

RLH is recognized throughout the U.S. and offers the only **UNCONDITIONAL LIFETIME WARRANTY** in the telecommunications industry. We are very proud of our warranty which simply states that our Fiber Optic Link Assemblies are warranted to be free of defects in material and workmanship for the **LIFE OF THE PRODUCT**.

We can offer this warranty because:

- We believe our customers shouldn't have to incur additional costs due to failure or damage
- We engineer and manufacture our Fiber Optic Links in the USA, with total confidence in our quality
- We understand how safety and reliability impact the total cost of ownership
- We know that customer support extends beyond the initial sale, so **we stand behind our products**

RLH will replace any product, or part thereof, that fails **FOR ANY REASON**, provided the defective part is returned to RLH Freight prepaid. This warranty is **UNCONDITIONAL** and valid even when RLH Fiber Optic Link Assemblies have been abused or mishandled, where unauthorized repairs have been attempted or performed, or product has been damaged as a result of a natural disaster. Compare this warranty to our competitors and see how our warranty will reduce your costs and simplify your maintenance activities.

To make a warranty claim, or schedule repair or replacement of your RLH product, please contact us for an RMA number. You will be promptly assisted by one of our warranty specialists. All returns must have an RMA number before we can receive any items.

Technical Support

Normal technical support: (Mon - Fri 6am - 6pm PST)	Local (714) 532-1672 Toll Free (800) 877-1672 Toll Free (866) DO-FIBER
24/7 Technical support:	(714) 366-2503 (714) 457-5740 (714) 396-8982

Contact Information

Corporate Headquarters:	RLH Industries, Inc. 936 N. Main Street Orange, CA 92867 USA
Phone:	Local (714) 532-1672 Toll Free (800) 877-1672 Toll Free (866) DO-FIBER
Fax:	(714) 532-1885
Email:	info@fiberopticlinc.com
Web site:	www.fiberopticlinc.com



RLH Industries, Inc.
936 N. Main Street, Orange, CA 92867 USA
T: (714) 532-1672
F: (714) 532-1885

Please contact your RLH sales representative for pricing and delivery information.

Specifications subject to change without notice.