

DS3/T3 Fiber Optic Link 4RU Plug-In Card

Introduction

The RLH DS3 Fiber Converter T3/E3 converts standard T3 (44.736Mbps) or E3 (34.368Mbps) coax to fiber conversion, and can be used by telco service providers and enterprise level users to connect to communication devices such as Utility, Wireless, PBX, Multiplexers, Routers and video servers via fiber optic cable.

Multimode and single-mode cards provide transmission of the DS3 data signals over a fiber optic facility to extend the circuit and provide dielectric isolation between the network and distant connection. The T3/E3 system operates in pairs, extending distances over fiber, improving noise immunity and quality of service while improving intrusion protection, high voltage communications protection and network security.

Key Features

- Critical DS3 environments such as Wireless, Utility and Military applications
- Provides T3/E3 DS3 coax-to-fiber conversion
- Supports B3ZS for T3 (DS3) and HDB3 for E3 codes
- Extends network span up to 2.5 Km (1.5 mi.) on multimode and 28 Km (16.8 mi.) on single-mode fiber
- Full duplex, constant transmission
- Framing independent - supports framed or unframed and channelized or fractional unchannelized data
- Supports B3ZS for T3 (DS3) and HDB3 for E3 codes
- Features user-selectable Local and Remote Loop-Back modes and Force 1's (AIS) to Coax and Fiber
- Individual coax and fiber port enable/disable
- Supports multimode and single-mode fiber with ST, SC and LC and connectors
- Convenient LED status indicators
- Meets ANSI, ETSI and ITU specifications
- Environmentally Rated for weather conditions
- Standard RLH 4RU form factor
- Covered by our **Exclusive Unconditional Lifetime Warranty**



DS3/T3
OVER FIBER

Contents

Introduction	1
General Safety Practices	2
Special Handling Requirements	2
Acronyms, Abbreviations	3
Application	3
Installation	4
System Diagrams	5
Installation	5
CO Installation	7
Sub Installation	8
Powering	9
LED Status	10
DIP Switch Settings	10
Troubleshooting	12
Specifications	13
Ordering Information	13
Warranty, Technical Support	14
Contact Information	14

Specifications subject to change without notice.

General Safety Practices

Intended Audience

This guide is intended for use by knowledgeable telco/network installation, operation and repair personnel. Every effort has been made to ensure the accuracy of the information in this guide is accurate. However, due to constant product improvement, specifications and information contained in this document are subject to change without notice.

Conventions

Symbols for notes, attention, and caution are used throughout this manual to provide readers with additional information, advice when special attention is needed, and caution to prevent injury or equipment damage.

The equipment discussed in this document may require tools designed for the purpose being described. RLH recommends that service personnel be familiar with the correct handling and use of any installation equipment used, and follow all safety precautions including the use of protective personal equipment as required.

Caution - Severe Shock Hazard

- Never install during a lightning storm or where unsafe high voltages are present.
- Active phone lines may carry high DC voltages. Use caution when handling copper wiring.

Warning

The intra-building port(s) of the equipment or subassembly is suitable for connection to intrabuilding or unexposed wiring or cabling only. The intra-building port(s) of the equipment **MUST NOT** be metallically connected to interfaces that connect to the OSP or its wiring. These interfaces are designed for use as intra-building interfaces only (Type 4 ports as described in GR-1089-CORE, Issue 4) and require isolation from the exposed OSP cabling. The addition of Primary Protectors is not sufficient protection in order to connect these interfaces metallically to OSP wiring.

Special handling requirements

Be careful when handling electronic components

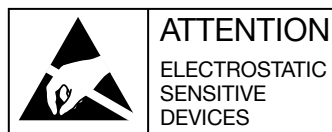

- This product contains static sensitive components.
- Handle Fiber Optic Link cards at their edges only.
- Follow proper electrostatic discharge procedures.

This card utilizes circuitry that can be damaged by static electricity. When transporting the card, carry it in an ESD safe container such as the antistatic bag provided with the card. Before handling cards, discharge yourself of static electricity by physical bodily contact with earth ground. When handling cards, hold by outer edges and avoid touching circuitry. Failure to follow ESD precautions may cause serious damage to the card and prevent proper operation.

Guidelines for handling terminated fiber cable

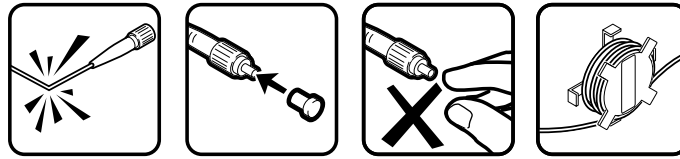

- Do not bend fiber cable sharply. Use gradual and smooth bends to avoid damaging glass fiber.
- Keep dust caps on fiber optic connectors at all times when disconnected.
- Do not remove dust caps from unused fiber.
- Keep fiber ends and fiber connectors clean and free from dust, dirt and debris. Contamination will cause signal loss.
- Do not touch fiber ends.
- Store excess fiber on housing spools or fiber spools at site

Acronyms

Commonly used acronyms and abbreviations

Acronym/Abbreviation	Description
CO	Central Office
Sub	Subscriber
TX	Transmit
RX	Receive
PWR	Power
RU	EIA Rack Unit (1.75")

Color abbreviations

Abbreviation	Color
BLU	Blue
GRN	Green
ORG	Orange
RED	Red
YEL	Yellow

Applications

Telecommunications equipment in high voltage areas can be at risk due to Ground Potential Rise (GPR). A copper network or phone cable referenced to a remote ground can become a path for high voltages during a ground fault. Placement of an all-dielectric fiber optic cable and locating the CO ADSL fiber card at either the 300 Volt Point (as determined by a GPR Engineering study) or at the nearest/safest telco service drop completely eliminates the presence of a copper cable into a high voltage environment. This design dramatically increases the overall safety of personnel and equipment involved.

The DS3/T3 system provides long distance service (up to 30km/18mi.) without any additional equipment. Fiber is immune to EMI/RF interference, ground loops, and high voltage surges from lightning or ground faults, and is ideal in electrically noisy environments such as near large power sources, electrical motors, and radio communications equipment.

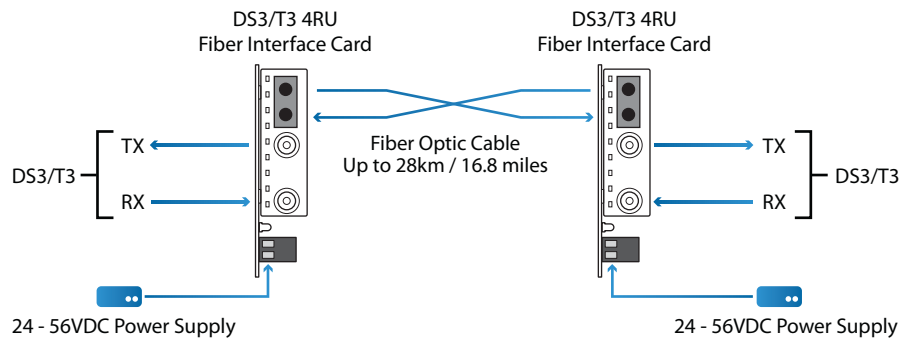

Typical DS3/T3 System Diagram

Installation

Before installing

- Check for shipping damage
- Check the contents to ensure correct model, mode and fiber connector type
- Have a clean, dry installation environment ready

CAUTION

- Never install during a lightning storm
- Use caution when handling copper wiring.
- This product incorporates static sensitive components. Handle the cards by their edges and follow proper electro-static discharge procedures Required for installation
- RLH card housing for 4RU plug-in cards
- 24-56VDC@100mA local power source for each card.

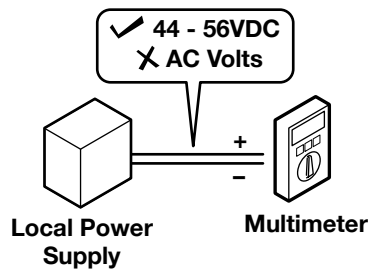

Note: In order to maintain high voltage isolation, Fiber Optic Link CO and Sub cards must be powered from separate isolated power sources.

Measure the DC voltage of the source power to ensure that it is 24-56VDC@100mA. All electrical and fiber optic connections are made directly onto the card. Use standard CAT-5, or 22-26 AWG solid wire for power connections to the card. The power input terminal is polarity sensitive.

Configure on-board DIP switches

The on-board DIP switch (S1) is located at the top edge of the card. The switch is marked with the ON position for the individual switch positions. Orient the card accordingly when referring to the switch diagram below. The card is set at the factory by default with switch 1 in the ON position.

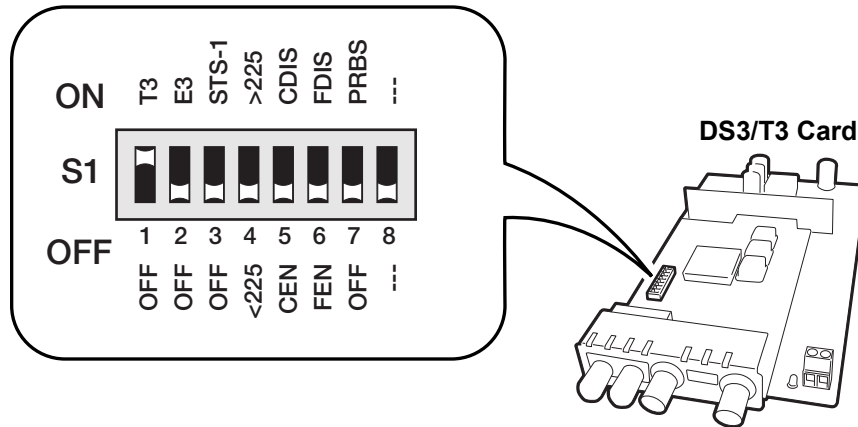

On-board S1 DIP Switch

Name	Position	Setting	Description
T3	1	ON	T3 protocol is selected
		OFF	T3 protocol is OFF
E3	2	ON	E3 protocol is selected
		OFF	E3 protocol is OFF
STS-1	3	ON	STS-1 protocol is selected
		OFF	STS-1 protocol is OFF
<225 / >225	4	ON	Coax build-out distance is greater than 225 ft. (68.5m)
		OFF	Coax build-out distance is less than 225 ft. (68.5m)
CEN / CDIS	5	ON	Coax port is disabled
		OFF	Coax port is enabled
FEN / FDIS	6	ON	Fiber port is disabled
		OFF	Fiber port in enabled
PRBS	7	ON	Forces pseudo random pattern out of the Coax TX (out) port
		OFF	Normal operation
Not Used	8	OFF	Not used

- **Note:** DIP switches 1, 2 and 3 may not be used at the same time.

T3, E3 and STS-1 Protocol Selection

When the “T3” DIP-switch is in the ON position, the T3 protocol is selected. When the “E3” DIP-switch is in the ON position, the E3 protocol is selected. When the “STS-1” DIP-switch is in the ON position, the STS-1 protocol is selected.

Only one of the three DIP-switches (T3, E3 and STS-1) may be in the ON position at any one time. The factory default setting of the module is T3 ON.

<225 / >225 - Coax Build-Out Distance Setting

When this DIP-switch is in the OFF position, a Coax build-out distance of less than 225 ft. (68.5m) is selected. When in the ON position, a distance of 225 ft. (68.5m) or higher is selected. Select the appropriate Coax distance for your application.

CEN/CDIS and FEN/FDIS - Port Control

When both DIP-switches are in the OFF position, the ports are enabled. When the CEN/CDIS switch is in the ON position, the coax port is disabled. When the FEN/FDIS switch is in the ON position, the fiber port is disabled.

PRBS - Pseudo Random Pattern Generator

When set to the ON position, the converter forces a pseudo random pattern out of the Coax TX (out) port. The data received at Fiber-In is discarded and the data at Coax RX (in) is passed through to Fiber-Out.

Note: Some combinations of DIP-switch settings are illegal, and will be indicated by the orange Fiber Test TST LED blinking quickly three times followed by a pause.

Configure front panel DIP switches

The front panel DIP switch is located at the front panel of the card, between the Coax connectors. This switch facilitates the testing of the fiber cables. The switch is marked with the ON position for the individual switch positions. Orient the card accordingly when referring to the switch diagram below. Moving the switch in the direction of the arrows turns the switch ON. The factory default setting is OFF.

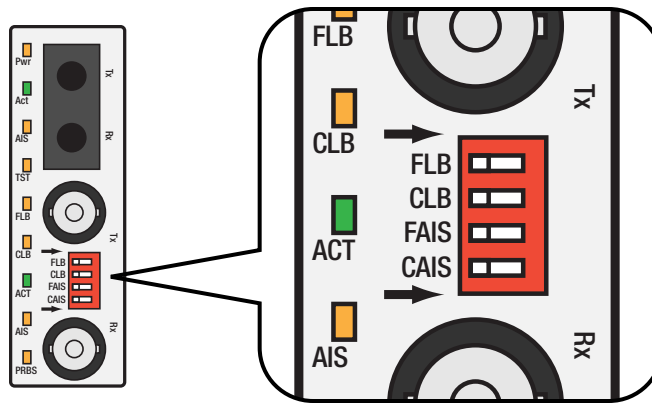

Front Panel DIP Switch

Name	Position	Setting	Description
FLB	1	ON	Local Fiber Loopback Mode is ON
		OFF	Normal operation
CLB	2	ON	Local Coax Loopback Mode is ON
		OFF	Normal operation
FAIS	3	ON	Force 1s to Fiber (AIS)
		OFF	Normal operation
CAIS	4	ON	Force 1s to Coax (AIS)
		OFF	Normal operation

FLB - Local Fiber Loopback Mode

When the FLB DIP switch is in the ON position, it sets the fiber port to a Local Fiber Loopback Mode and the orange FLB LED is turned on. When in this mode, data received at the Fiber RX is forwarded to the BNC TX and the fiber TX. If no data is received at Fiber RX, an AIS pattern is transmitted out both the BNC TX and Fiber TX. By returning the DIP switch to the OFF position, the unit resumes normal operation.

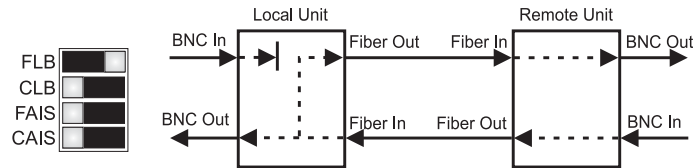

Local Loopback Mode Diagram

CLB - Coax Loopback

This switch enables the testing of the coax cables. When the CLB switch is in the ON position, it sets the coax port to a Local Coax Loopback Mode, and the orange CLB LED is turned on. When in this mode, data received at the BNC RX is forwarded to the BNC TX and the Fiber TX. If no data is received at BNC RX, an AIS pattern is transmitted out both BNC TX and Fiber TX. By returning the DIP switch to the OFF position, the unit resumes normal operation.

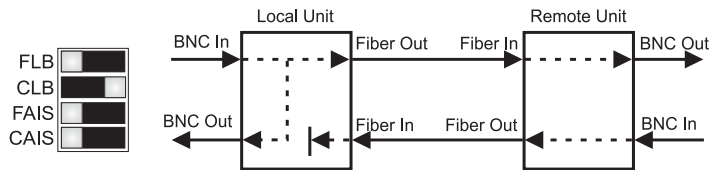

Coax Loopback Mode Diagram

FLB + CLB - Remote Loopback Mode

When both the FLB and CLB DIP switches are in the ON position, they force the remote unit at the other end of the fiber link to loop back its fiber and coax ports. This facilitates test of the fiber cables and the remote unit without having to physically set DIP-switches on the remote unit. While in this mode, the local unit's BNC is set to a local loopback, and its FLB and CLB LEDs are turned on.

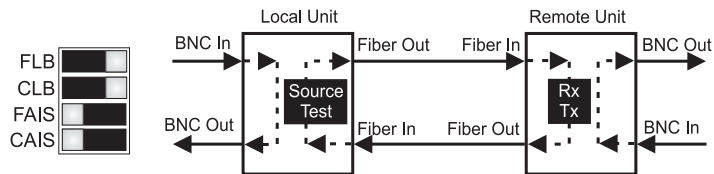

Remote Loopback Mode Diagram

While in the remote loopback mode, the local unit sends a test pattern to the remote unit. This pattern forces the remote unit into the loopback mode and is also returned back to the local unit. When forced into the remote loopback mode, the remote unit's FLB and CLB LEDs blink slowly (1Hz).

When the test pattern is received successfully at the local unit's Fiber RX, the TST LED blinks rapidly (10Hz). Any other data causes slow blinking (1Hz) on the TST LED. If no data is returned to Fiber RX, the LED is turned OFF.

Returning both DIP-switches to the OFF position, causes the local and remote units to resume normal operation.

FAIS - Force 1s to Fiber (AIS)

When the FAIS DIP switch is in the ON position, an "all ones" pattern is forced out the Fiber TX port. The Coax RX data is discarded and Fiber RX data is passed through to BNC TX. By returning the DIP switch to the OFF position, the unit resumes normal operation.

CAIS - Force 1s to Coax (AIS)

When the CAIS DIP switch is in the ON position, an "all ones" pattern is forced out the BNC TX port. The Fiber RX data is discarded and BNC RX data is passed through to Fiber TX. By returning the DIP switch to the OFF position, the unit resumes normal operation.

Install card into housing

Handle card by edges. Install in slot 1 or next available card slot. Install card into housing before connecting. An RLH 5 Card Shelf is shown in the illustration below, but wall mount and outdoor rated enclosures have similar card slot arrangements.

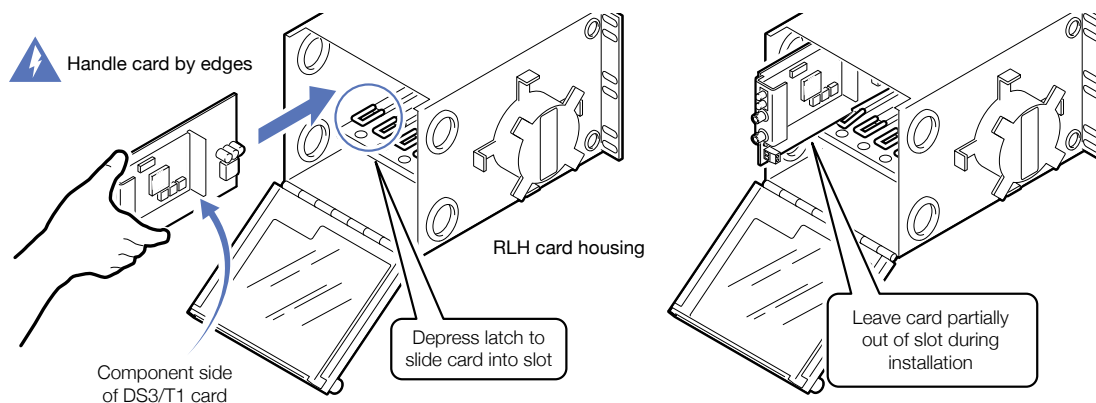

Typical installation into 5 card shelf

Connect Cables

Connect BNC Cables

Connect the BNC cables to the T3/E3 converter and attach the other end of the cables to appropriate network equipment. The TX must attach to the RX and the RX must attach to the TX.

Connect Fiber Cables

Connect an appropriate multimode or single-mode fiber cable to the fiber port of the installed module.

It is important to ensure that the TX (Transmit) is attached to the RX (Receive) side of the card at the other end, and the RX is attached to the TX side.

Connect Power

Connect 24-56VDC local power to the **AUX .PS.** screw down terminal. The power input is polarity sensitive, be sure to connect the positive power wire to the + side of the terminal.

Operation

Once the DS3/T3 system has been installed and configured per the steps described in the Installation section, verify system operation by viewing the front panel LED indicators.

- The Power LED indicates the module is receiving power.
- The Fiber Optic link LED indicates the fiber optic connection has been established.
- The Coax LED indicates a T3/E3 signal has been detected.

LED Status

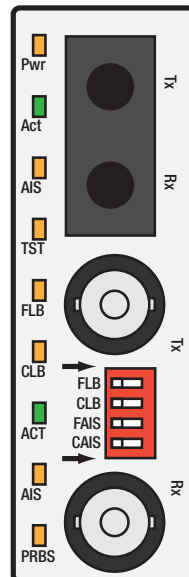

DS3/T3 Front Panel LEDs

Front Panel LEDs

LED	Color		Condition	Description
Pwr	ORG	Power	ON	Power is available
			OFF	Power is OFF
Act	GRN	Fiber Activity	Fast Blink (10Hz)	Data being received
			OFF	No valid data
AIS	ORG	Fiber AIS	Fast Blink (10Hz)	AIS received
			OFF	AIS detection OFF
TST	ORG	Fiber Test Detected	Fast Blink (10Hz)	Local unit asserting Remote Loopback, test pattern received
			Slow Blink (1Hz)	Local unit asserting Remote Loopback, unexpected pattern received
			3 Quick Blinks (2Hz) and Pause (1sec.)	Illegal DIP switch selection
FLB	ORG	Fiber Loopback	ON	Local Fiber Loopback. If CLB LED also ON, indicates that the unit is the Local Unit in Remote Loopback Mode.
			Slow Blink (1Hz)	Together with CLB LED in slow blink, indicates that the unit is the Remote Unit in Remote Loopback Mode.
			OFF	Normal operation
CLB	ORG	Coax Loopback	ON	Local Coax Loopback. If FLB LED also ON, indicates that the unit is the Local Unit in Remote Loopback Mode.
			Slow Blink (1Hz)	Together with FLB LED in slow blink, indicates that the unit is the Remote Unit in Remote Loopback Mode.
			OFF	Normal operation
ACT	GRN	Coax Activity	Fast Blink (10Hz)	Data being received
			OFF	No valid data
AIS	ORG	Coax AIS Detected	Fast Blink (10Hz)	AIS received
			OFF	AIS detection OFF
PRBS	ORG	Coax PRBS Detected	Fast Blink (10Hz)	PRBS Received
			Slow Blink (1Hz)	Forcing PRBS onto BNC TX
			OFF	PRBS detection/transmission OFF

Troubleshooting

If trouble is encountered:

- Verify all copper and fiber connections and settings.
- Refer to the LED table for operational status.

If trouble persists, replace the unit and retest. If technical assistance is required, contact RLH Industries, Inc. technical support department:

800-877-1672 (6 am to 6 pm- PST),
or call our 24/7 Technical/Customer Service: (714) 366-2503 or (714) 457-5740

General Specifications

Protocols	ANSI: T1.102, T1.107, T1.403, T1.404, T1-404a (T3), T1-408
	ITU: G703 (E3), G704, G706, G751, G921, G926, O.151
	ETSI: EN 300 689, 300 686, 300 687
Data Rates	T3: (44.736Mbps)
	E3: (34.368Mbps)
Copper Interface	RG-59 Coax 75 ohm, BNC
Copper Distance	T3: 1245 feet (380 m)
	E3: 1445 feet (440 m)
Transmission method	Amplitude Modulated Light via two optical fibers
	Multimode: 850nm
	Single-mode: 1310nm
Fiber Type	ST, SC or LC fiber female connectors
	Multimode: 62.5/125µm, 50/125µm
	Single-mode: 8-9/125µm
Maximum Fiber Distance	Multimode: 5km / 3 miles
	Single-mode: 30km / 18 miles
Power Requirements	Local DC power source 24-56VDC@100mA
Power Wire Terminals	Screw clamp terminal block, 16 ~ 26 AWG
Operating Temperature	-40°F to +140°F (-40°C to +60°C)
Humidity	0~95% non-condensing
Dimensions	RLH 4RU Plug-in Card, L7" x W4"x H1.24"

Ordering Information

A complete system comprises a CO and a Sub card. DS3/T3 part numbers are located on the card.

Fiber Type	Distance	Side	Connector	Part Number
Multimode *	5km / 3 miles	CO	LC	8804-1501-01
			ST	8806-1501-01
			SC	8805-1501-01
		Sub	LC	8804-1511-01
			ST	8806-1511-01
			SC	8805-1511-01
Single Mode	30km / 18 miles	CO	LC	8804-1509-01
			ST	8806-1509-01
			SC	8805-1509-01
		Sub	LC	8804-1519-01
			ST	8806-1519-01
			SC	8805-1519-01

► * 62.5µm multimode fiber compatibility is standard, add **-50** to part number for 50µm fiber compatibility

Warranty

RLH is recognized throughout the U.S. and offers the only **UNCONDITIONAL LIFETIME WARRANTY** in the telecommunications industry. We are very proud of our warranty which simply states that our Fiber Optic Link Assemblies are warranted to be free of defects in material and workmanship for the **LIFE OF THE PRODUCT**.

We can offer this warranty because:

- We believe our customers shouldn't have to incur additional costs due to failure or damage
- We engineer and manufacture our Fiber Optic Links in the USA, with total confidence in our quality
- We understand how safety and reliability impact the total cost of ownership
- We know that customer support extends beyond the initial sale, so **we stand behind our products**

RLH will replace any product, or part thereof, that fails **FOR ANY REASON**, provided the defective part is returned to RLH Freight prepaid. This warranty is **UNCONDITIONAL** and valid even when RLH Fiber Optic Link Assemblies have been abused or mishandled, where unauthorized repairs have been attempted or performed, or product has been damaged as a result of a natural disaster. Compare this warranty to our competitors and see how our warranty will reduce your costs and simplify your maintenance activities.

To make a warranty claim, or schedule repair or replacement of your RLH product, please contact us for an RMA number. You will be promptly assisted by one of our warranty specialists. All returns must have an RMA number before we can receive any items.

Technical Support

Normal technical support: (Mon - Fri 6am - 6pm PST)	Local (714) 532-1672 Toll Free (800) 877-1672 Toll Free (866) DO-FIBER
24/7 Technical support:	(714) 396-8982 (714) 457-5740

Contact Information

Corporate Headquarters:	RLH Industries, Inc. 936 N. Main Street Orange, CA 92867 USA
Phone:	Local (714) 532-1672 Toll Free (800) 877-1672 Toll Free (866) DO-FIBER
Fax:	(714) 532-1885
Email:	info@fiberopticlink.com
Web site:	www.fiberopticlink.com



RLH Industries, Inc.
936 N. Main Street, Orange, CA 92867 USA
T: (714) 532-1672
F: (714) 532-1885

Please contact your RLH sales representative for pricing and delivery information.

Specifications subject to change without notice.