

2 Channel ADSL Over Fiber System 4RU Plug-in Card

Dual ADSL Over a Single Fiber Pair

Introduction



The RLH 2 Channel ADSL 4RU Fiber Optic Link System supports two channels of ADSL copper service over a single pair of single mode or multimode fiber optic cable. This environmentally hardened system converts the copper signals into an optical signal over fiber, then converts the fiber optic signal back into 2 Wire DSL copper service for customer use.

Transmitting ADSL signals over fiber optic cable allows for network extension over long distances, and provides electrical isolation between both ends of the network. The RLH ADSL fiber system is compatible with DSL download data rates of up to 2.75Mbps.

Each ADSL fiber optic link card requires a 44-56VDC 100mA local power source to operate. RLH carries several compatible power supplies, but any compatible DC power source is acceptable.

This hardened, rugged system is covered by our **Exclusive Unconditional Lifetime Warranty**.

Key Features

- Covered by our **Exclusive Unconditional Lifetime Warranty**
- Extends network span up to 2 miles (3.2km) on multimode and up to 6 miles (9.6km) on single-mode fiber
- Environmentally hardened to operate in -40°F to +158°F (-40°C to +70°C) environments
- Ideal for critical, high voltage, remote or un-manned locations that must remain operating 24/7/365
- Provides absolute high voltage protection from remote grounds by using all-dielectric fiber optic cable instead of copper
- Each card can accept 2 ADSL lines, maximizing throughput
- Convenient LED status indicators
- Standard RLH 4RU plug-in card form factor



RLH 2 Channel ADSL 4RU Plug-in Card

Contents

Introduction	1
General Safety Practices	2
Special Handling Requirements	2
Acronyms, Abbreviations	3
Application	3
Installation	4
System Diagrams	5
Powering	9
LED Status	10
Setting the Optical Gain	11
Troubleshooting	12
Specifications	13
Ordering Information	13
Warranty, Technical Support	14
Contact Information	14

Compliance Information

The RLH ADSL Fiber Optic Link System is compliant with the following industry standards:

ADSL: G.DMT, G.LITE, ANSI T1.413 Issue2, RE-ADSL
 FCC PART-15, FCC PART-68B
 IEEE802.1d, 802.3, and 802.3u
 BR 876-310-100 BT (Telcordia)
 Bellcore SR-3966, Motorola R56
 GR-1089, GR-63

General Safety Practices

Intended Audience

This guide is intended for use by knowledgeable telco/network installation, operation and repair personnel. Every effort has been made to ensure the accuracy of the information in this guide is accurate. However, due to constant product improvement, specifications and information contained in this document are subject to change without notice.

Conventions

Symbols for notes, attention, and caution are used throughout this manual to provide readers with additional information, advice when special attention is needed, and caution to prevent injury or equipment damage.

The equipment discussed in this document may require tools designed for the purpose being described. RLH recommends that service personnel be familiar with the correct handling and use of any installation equipment used, and follow all safety precautions including the use of protective personal equipment as required.

Caution - Severe Shock Hazard

- Never install during a lightning storm or where unsafe high voltages are present.
- Active phone lines may carry high DC voltages. Use caution when handling copper wiring.
- Active ADSL lines may carry high DC voltages. Use caution when handling ADSL wiring.

Warning - HVP Applications

The intra-building port(s) of the equipment or subassembly is suitable for connection to intrabuilding or unexposed wiring or cabling only. The intra-building port(s) of the equipment **MUST NOT** be metallically connected to interfaces that connect to the OSP or its wiring. These interfaces are designed for use as intra-building interfaces only (Type 4 ports as described in GR-1089-CORE, Issue 4) and require isolation from the exposed OSP cabling. The addition of Primary Protectors is not sufficient protection in order to connect these interfaces metallically to OSP wiring.

Special Handling Requirements

Be careful when handling electronic components

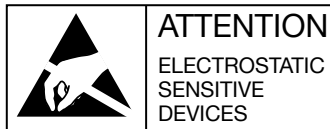

- This product contains static sensitive components.
- Handle Fiber Optic Link cards at their edges only.
- Follow proper electrostatic discharge procedures.

This card utilizes circuitry that can be damaged by static electricity. When transporting the card, carry it in an ESD safe container such as the antistatic bag provided with the card. Before handling cards, discharge yourself of static electricity by physical bodily contact with earth ground. When handling cards, hold by outer edges and avoid touching circuitry. Failure to follow ESD precautions may cause serious damage to the card and prevent proper operation.

Guidelines for handling terminated fiber cable

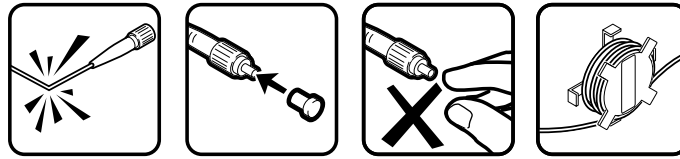

- Do not bend fiber cable sharply. Use gradual and smooth bends to avoid damaging glass fiber.
- Keep dust caps on fiber optic connectors at all times when disconnected.
- Do not remove dust caps from unused fiber.
- Keep fiber ends and fiber connectors clean and free from dust, dirt and debris. Contamination will cause signal loss.
- Do not touch fiber ends.
- Store excess fiber on housing spools or fiber spools at site

Acronyms

Commonly used acronyms and abbreviations

Acronym/Abbreviation	Description
CO	Central Office
Sub	Subscriber
CPE	Customer Premises Equipment
POTS	Analog Phone Service (Plain Old Telephone Service)
TX	Transmit
RX	Receive
PWR	Power

Color abbreviations

Abbreviation	Color
BLU	Blue
GRN	Green
ORG	Orange
RED	Red
YEL	Yellow

Applications

Telecommunications equipment in high voltage areas can be at risk due to Ground Potential Rise (GPR). A copper network or phone cable referenced to a remote ground can become a path for high voltages during a ground fault. Placement of an all-dielectric fiber optic cable and locating the CO ADSL fiber card at either the 300 Volt Point (as determined by a GPR Engineering study) or at the nearest/safest telco service drop completely eliminates the presence of a copper cable into a high voltage environment. This design dramatically increases the overall safety of personnel and equipment involved.

The RLH ADSL system provides long distance service (up to 9.6km/6mi.) without any additional equipment. Utilizing fiber for ADSL transmission has many advantages over copper wire. Fiber optic cabling is immune to EMI/RF interference, ground loops, and high voltage surges from lightning or ground faults, and is ideally suited for use in electrically noisy environments such as near large power sources, electrical motors, and radio communications equipment.

Installation

Before installing

- Check for shipping damage
- Check the contents to ensure correct model, mode and fiber connector type
- Have a clean, dry installation environment ready

CAUTION

- Never install during a lightning storm
- Active ADSL lines may carry high DC voltages up to 210V. Use caution when handling copper wiring.
- This product incorporates static sensitive components. Handle the cards by their edges and follow proper electro-static discharge procedures

Required for installation

- 44-56VDC 5W power source for each card.

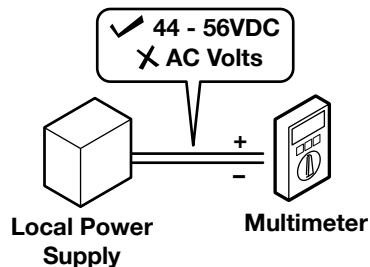

Note: To maintain high voltage isolation, Fiber Optic Link CO and Sub cards must be powered from separate isolated power sources.

Measure the DC voltage of the source power to ensure that it is 44-56VDC@100mA. All electrical and fiber optic connections are made directly onto the card. Use standard CAT-5E or better, 22-26 AWG solid wire for all copper wire connections to the card.

- RLH card housing for 4RU plug-in cards
- POTS splitter filter for each ADSL line on the CO side

Note: If 2 wire POTS voice grade service is required over fiber, a separate POTS fiber optic system is required as shown in the ADSL System Connection Diagram.

System Diagrams

A typical ADSL system will include 1 or 2 channels of ADSL.

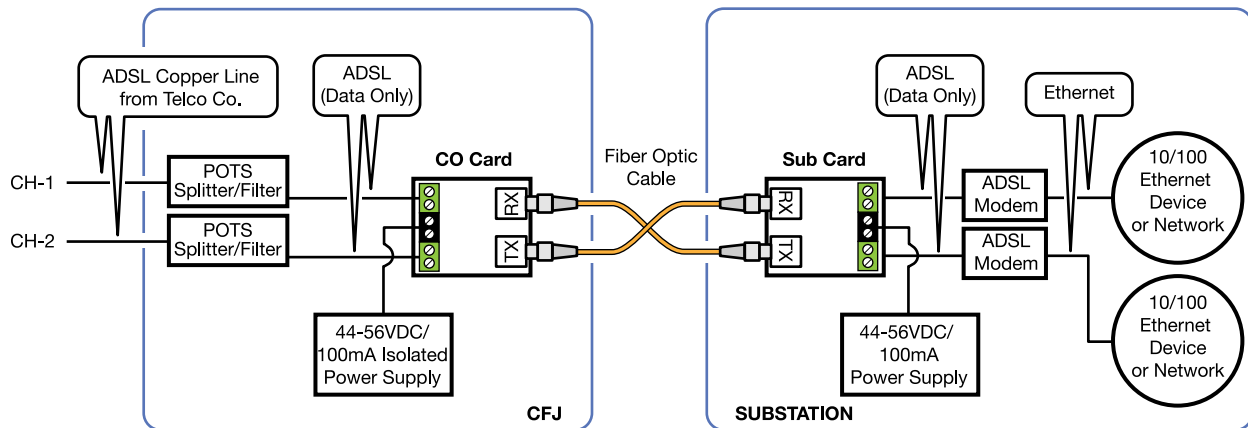

Typical 2 channel ADSL system diagram

The ADSL system may be used in conjunction with the RLH 2 Wire POTS System to provide analog phone service without requiring additional copper phone lines. The POTS may be line powered by the ADSL copper lines. Contact RLH for additional information on adding the optional POTS system.

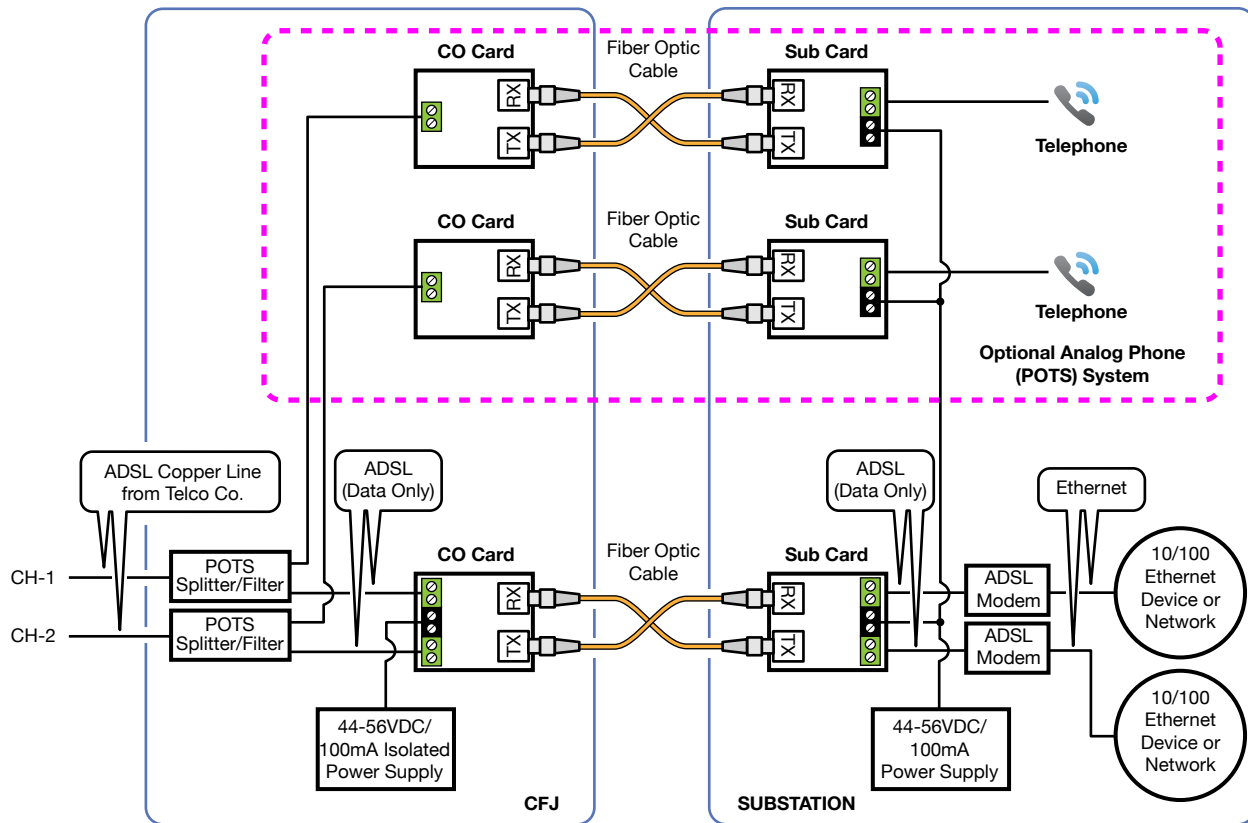

Typical 2 channel ADSL system with optional POTS system

Setting the Switch

The 4 position DIP switch located on the CO and Sub ADSL cards are shipped with default factory settings. Positions 1 and 2 on the DIP switch enable and disable the connections made at the LOOP1 and LOOP2 terminals respectively. Position 3 and 4 switches are not used and should remain OFF.

When first setting up the system, verify that switch settings are in the default positions.

Switch Position	Default Setting
1	ON
2	OFF
3	OFF
4	OFF

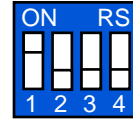

Default Switch Settings

Install card into housing

Handle card by edges. Install in slot 1 or next available card slot. Install card into housing before connecting. An RLH 5 Card Shelf is shown in the illustration below, but wall mount and outdoor rated enclosures have similar card slot arrangements.

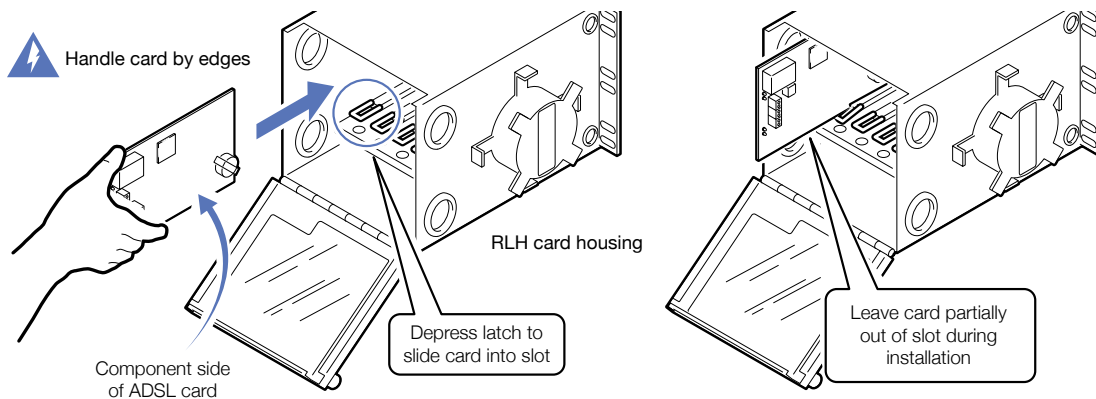

Typical installation into 5 card shelf

CO Side Installation

Connect fiber optic cable

Multimode and single-mode ADSL cards are equipped with either two ST or SC female optical connectors. Connect fibers to the TX (Transmit) and RX (Receive) optical connectors. The TX connector of each card must be connected to the RX connector of the other card.

- Save the dust cap for later use if the card is removed from service.
- Set each fiber connector firmly but carefully into the ADSL fiber connector.
- Route fiber cable loosely, avoiding kinks or tight bends.

Connect ADSL lines

Install POTS splitters on each ADSL line to help filter noise from the system. Once the splitter is connected, the ADSL copper connections are made at the screw down terminals at the front of the card. When using the optional RJ-45 connectors, simply connect to the desired port on the card.

Install each incoming ADSL copper pair into **LOOP2** and **LOOP2** terminals. **NOTE:** When using just one ADSL line, use the LOOP1 terminal and turn DIP Switch 2 to OFF to improve performance by reducing noise and crosstalk.

Connection using optional RJ connector

RJ-48C jacks may be pre-installed or obtained separately.

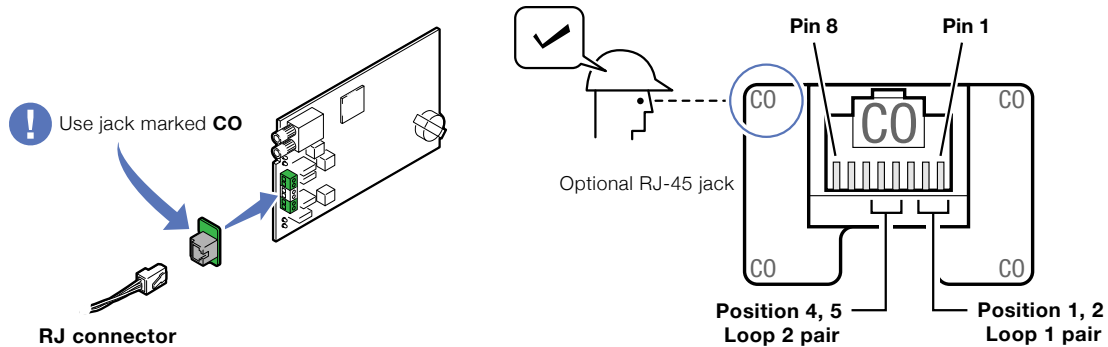

Connect Power

Connect 44-56VDC local power to the **AUX .P.S.** screw down terminal. The power input is not polarity sensitive.

When power is applied and 2 ADSL lines are connected and active, the blue **PWR** LED and green **LOOP1** and **LOOP2** LEDs will be **ON**.

Sub Side Installation

Connect fiber optic cable

Multimode and single-mode ADSL cards are equipped with either two ST or SC female optical connectors. Connect fibers to the TX (Transmit) and RX (Receive) optical connectors. Make sure the connectors are flipped so that the TX connector of each card is connected to the RX connector of the other card.

- Save the dust cap for later use if the card is removed from service.
- Set each fiber connector firmly but carefully into the ADSL fiber connector.
- Route fiber cable loosely, avoiding kinks or tight bends.

Connect ADSL lines

The ADSL copper connections are made at the screw down terminals at the front of the card. Install each Sub side ADSL copper pair into **LOOP2** and **LOOP2** terminals. When using the optional RJ-45 connectors, simply connect to the desired port on the card.

NOTE: When using just one ADSL line, use the LOOP1 terminal and turn DIP switch position 2 to OFF to improve performance by reducing noise and crosstalk.

Connection using optional RJ connector

RJ-48C jacks may be pre-installed or obtained separately.

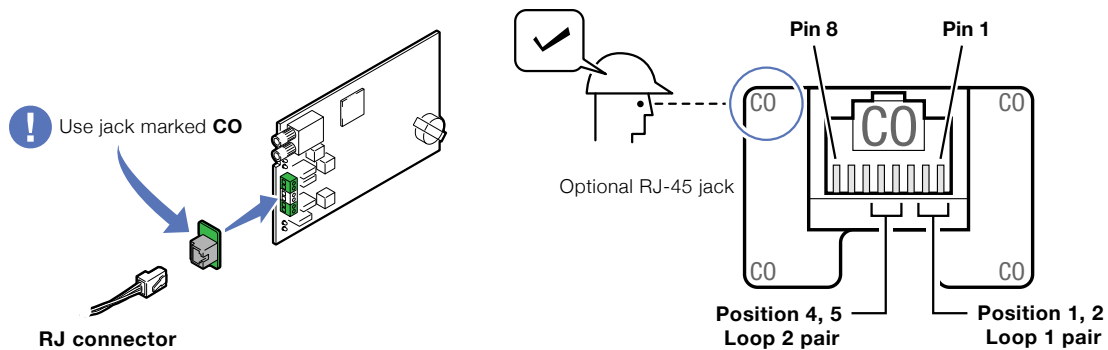

Connect Power

Connect 44-56VDC local power to the **AUX .P.S.** screw down terminal. The power input is not polarity sensitive.

When power is applied and 2 ADSL lines are connected and active, the blue **PWR** LED and green **LOOP1** and **LOOP2** LEDs will be **ON**.

Powering

- The RLH ADSL CO and Sub cards require a local DC source of 44-56 Volts and draws 5 Watts. Power is connected to the black screw down terminal labeled 44-56VDC AUX. P.S. The AUX. P.S. input is not polarity sensitive.]
- Use standard 24-26 AWG CAT-5 or equiv. cable for DC power connections. Strip back enough insulation to insure a good DC power connection to ADSL card.
- RLH manufactures switching AC/DC or DC/DC power supplies designed for this application. Refer to the power supply table below.

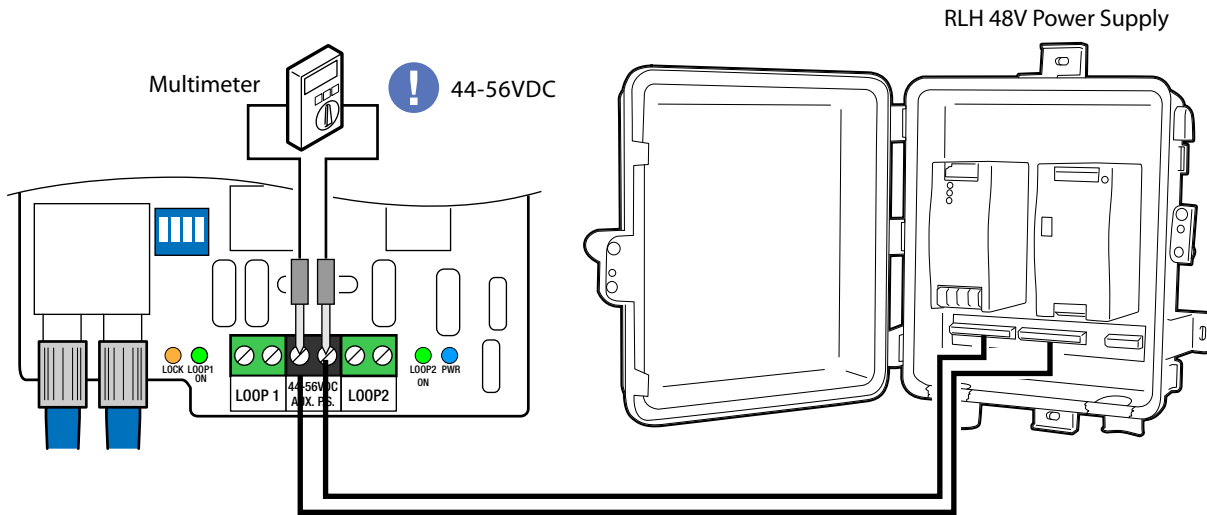

Part Number	Description	Powering Capacity
8806-1204-01	115/48V AC/DC power supply with 1.2A battery backup	5 ADSL cards
8806-1214-01	115/48V AC/DC power supply with 7.0A battery backup	17 ADSL cards
8806-1276-02	130/48V DC/DC Converter	12 ADSL cards
8806-1266-02	24/48V DC/DC Converter	12 ADSL cards

Common RLH AC/DC & DC/DC power supplies. Also see www.fiberopticlink.com

LED Status

There are four (4) Light Emitting Diodes (L.E.D.s) that display operational status of the RLH ADSL Card. On the topside of the card near the Optical Transceiver are the LOCK and LOOP1 LEDs. Below the connectors are the LOOP2 and Power LEDs.

Normal operation – When both cards are powered and connected through fiber, Orange LOCK LED is ON, Blue Power LED is ON and Optional Green Channel LEDs are ON if selected.

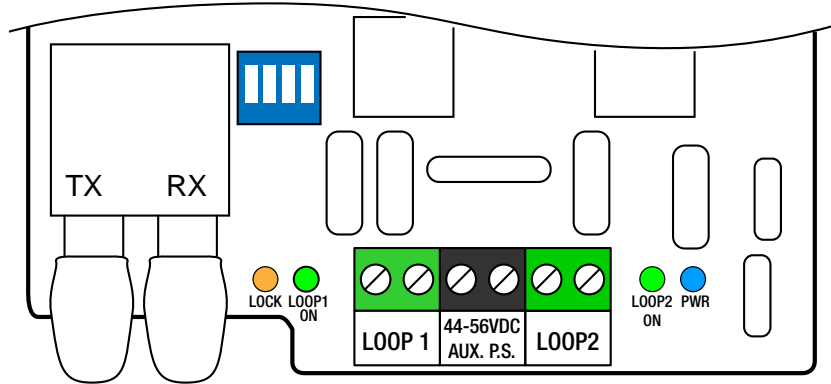

LED	Color	Condition	Description
LOCK	ORG	ON	Fiber communication is OK
		Blinking	Fiber communications FAIL
LOOP1	GRN	ON	DIP switch 1 is ON
		OFF	DIP switch 1 is OFF
LOOP2	GRN	ON	DIP switch 2 is ON
		OFF	DIP switch 2 is OFF
POWER	BLU	ON	Power is supplied to the card
		OFF	Power is not being supplied to the card

DIP Switch Settings

The ADSL card has a DIP switch with 4 positions for switching loop terminals off or on, and for setting the optical gain.

Position	Setting	Description
1	ON	Turns LOOP 1 ON
	OFF	Turns LOOP 1 OFF
2	ON	Turns LOOP 2 ON
	OFF	Turns LOOP 2 OFF

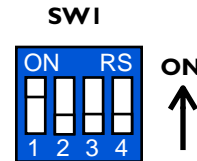

Positions 1 and 2 turn the LOOP1 and LOOP2 wire connection terminals ON and OFF. When using just one ADSL line, use the ADSL LOOP1 connection terminal and set switch position 2 to OFF. This will improve performance by reducing noise and crosstalk.

Setting the Optical Gain

DIP switch positions 3 and 4 are used for setting the gain depending on the type of circuit the ADSL system is connected to.

The factory default setting is OFF for positions 3 and 4, corresponding to 0dB gain, and will function normally in most installations. The switch settings will not require adjustment unless the ADSL modem on the SUB side fails to communicate properly with the signal from the fiber link card.

Before adjusting the gain, verify all copper and fiber connections. Refer to the LED status section to verify correct fiber, power and ADSL operation.

To change the gain:

1. Estimate the effective maximum copper cable length from the CO or nearest repeater to the ADSL CO card.
2. Find the recommended CO and SUB gain settings using the gain charts.
3. Set switch positions 3 and 4 accordingly, using the switch settings table.

Check the ADSL modem for communication status after setting the switches. More than one setting may be tried before finding the optimum gain setting. Using an incorrect gain setting will not harm the system, but may prevent the ADSL modem from communicating properly with the fiber card.

Determining Effective Maximum Copper Cable Length

Estimate the maximum length of copper cable in feet, between the Central Office (or the nearest repeater) and the ADSL CO Fiber Card. For best results, chose the gain setting where the estimated length falls in the middle of the matching color bar.

For 24 AWG

CO	SUB	0 ft	1K ft	2K ft	3K ft	4K ft	5K ft	6K ft	7K ft	8K ft	9K+ ft
-6dB	0dB										
0dB	0dB										
0dB	-3dB										
0dB	-6dB										
+6dB	-6dB										
+9dB	-9dB										

For 26 AWG

CO	SUB	0 ft	1K ft	2K ft	3K ft	4K ft	5K ft	6K ft	7K ft	8K+ ft
-6dB	0dB									
0dB	0dB									
0dB	-3dB									
0dB	-6dB									
+6dB	-6dB									
+9dB	-9dB									

Set the Gain switches

Once a gain figure has been determined, set the gain by using switch positions 3 and 4.

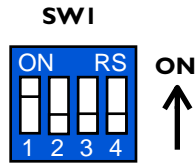

For CO Card			For Sub Card		
Gain/Attenuation	Switch Position		Gain/Attenuation	Switch Position	
	3	4		3	4
0dB	OFF	OFF	0dB	OFF	OFF
+6dB	OFF	ON	-6dB	OFF	ON
-6dB	ON	OFF	-3dB	ON	OFF
+9dB	ON	ON	-9dB	ON	ON

- Setting a gain switch on the CO card affects gain in the direction of the CO to SUB card.
- Setting a gain switch on the SUB card affects gain in the direction of the SUB to CO card.

Troubleshooting

If trouble is encountered, verify all copper and fiber connections and settings.

LED	Color	Condition	Meaning	Items to Check
LOCK	ORG	Blinking or OFF	Fiber port communication is poor or missing	Fiber connectors are clean and seated properly
				The TX fiber from each card is attached to the RX connector of the other card
				Test the fiber cable for damage
				Make sure both cards have power
LOOP1	GRN	OFF	Loop 1 terminal disabled	Turn DIP switch 1 ON to enable LOOP1
LOOP2	GRN	OFF	Loop 2 terminal disabled	Turn DIP switch 2 ON (If used) to enable LOOP2
POWER	BLU	OFF	Power not present at power terminal	Ensure power source is functioning
				Inspect copper wiring from power source to ADSL card
				Test the power for 44~56VDC, 5W

If trouble persists, replace the unit and retest. If technical assistance is required, contact our technical support department. Refer to the Technical Support information at the end of this guide.

General Specifications

Transmission method	Amplitude Modulated Light via two optical fibers	
	Multimode:	850nm
	Single-mode:	1310nm
Maximum Fiber Attenuation / Distance	Multimode:	14dB / 2 miles (3.2km)
	Single-mode:	8dB / 6 miles (9.6km)
Fiber Type	ST or SC fiber female connectors	
	Multimode:	62.5/125µm, 50/125µm
	Single-mode:	8-9/125µm
Insertion Loss	0dB+/-0.5dB each direction	
Maximum Data Rate	Downstream	2.75Mbps
	Upstream	2.75Mbps
Surge Protection	Varistors, Zener Diodes, PTC Thermistors, Diodes	
Power Requirements	CO	44-56VDC, 100mA minimum
	Sub	44-56VDC, 100mA minimum
Powering Method	CO	Local DC power source
	Sub	Local DC power source
LED Indicators	LOCK (ORG LED)	Card communication over fiber status
	LOOP1 (GRN LED)	ADSL line 1 ON/OFF
	LOOP2 (GRN LED)	ADSL line 2 ON/OFF
	PWR (BLU LED)	Power ON/OFF
Wire Terminals	Screw clamp terminal block, 16 ~ 26 AWG	
	Optional RJ-45 jack	
Operating Temperature	-40F to 160F (-40C to 70C) + Max Solar Load	
Humidity	95% non-condensing	
Dimensions	RLH 4RU Plug-in Card, L7" x W4" x H1.24"	
Standards Compliance	IEEE802.1d, 802.3, and 802.3u	
	ADSL: G.DMT, G.LITE, ANSI T1.413 Issue2, RE-ADSL	
	FCC PART-15, FCC PART-68B	
	Motorola R56, BR 876-310-100 BT (Telcordia), Bellcore SR-3966, GR-1089, GR-63	

Ordering Information

A complete system comprises a CO and a Sub card. ADSL part numbers are located on the card.

Fiber Type	ADSL CO Card	ADSL Sub Card
Multimode ST *	8806-1550-01	8806-1560-01
Multimode SC *	8805-1550-01	8805-1560-01
Single Mode ST	8806-1570-01	8806-1580-01
Single Mode SC	8805-1570-01	8805-1580-01

- ▶ * 62.5µm multimode fiber compatibility is standard, add **-50** to part number for 50µm fiber compatibility
- ▶ To add RJ-45 copper input instead of screw-down input, add -RJ at the end of the UHDSL card part number.
- ▶ Example part number: 8806-1550-01-RJ = ADSL CO Multimode w/ ST fiber connectors and RJ-45 jacks.

Warranty

RLH is recognized throughout the U.S. and offers the only **UNCONDITIONAL LIFETIME WARRANTY** in the telecommunications industry. We are very proud of our warranty which simply states that our Fiber Optic Link Assemblies are warranted to be free of defects in material and workmanship for the **LIFE OF THE PRODUCT**.

RLH will replace any product, or part thereof, that fails **FOR ANY REASON**, provided the defective part is returned to RLH Freight prepaid. This warranty is **UNCONDITIONAL** and valid even when RLH Fiber Optic Link Assemblies have been abused or mishandled, where unauthorized repairs have been attempted or performed, or product has been damaged as a result of a natural disaster. Compare this warranty to our competitors and see how our warranty will reduce your costs and simplify your maintenance activities.

To make a warranty claim, or schedule repair or replacement of your RLH product, please contact us for an RMA number. You will be promptly assisted by one of our warranty specialists. All returns must have an RMA number before we can receive any items.

Technical Support

Normal technical support: (Mon - Fri 6am - 6pm PST)	Local (714) 532-1672 Toll Free (800) 877-1672 Toll Free (866) DO-FIBER
24/7 Technical support:	(714) 396-8982 (714) 457-5740

Contact Information

Corporate Headquarters:	RLH Industries, Inc. 936 N. Main Street Orange, CA 92867 USA
Phone:	Local (714) 532-1672 Toll Free (800) 877-1672 Toll Free (866) DO-FIBER
Fax:	(714) 532-1885
Email:	info@fiberopticlink.com
Web site:	www.fiberopticlink.com



RLH Industries, Inc.
936 N. Main Street, Orange, CA 92867 USA
T: (714) 532-1672
F: (714) 532-1885

Please contact your RLH sales representative for pricing and delivery information.

Specifications subject to change without notice.