

4 Wire 56k DDS Interface, 4RU Fiber Optic Link System®

NEBS Level 3 Certified

Description

The RLH 4-Wire 56k DDS Fiber Optic Link System processes incoming bipolar signals (3.2V P-P Max) with digital data signal rates from 4.8 to 64kbps. It also supports analog data with bandwidth of 1 to 300kHz from 19.2 to 64kbps. Electrical signals received from the copper pairs are converted into optical signals and transmitted in both directions through fiber optic cable. The optical signals are converted back to electrical signals and transmitted to the copper pairs at the other end. The system supports remote loopback testing from the CO. This hardened, rugged system is covered by our **Exclusive Unconditional Lifetime Warranty**.

56k DDS CO Side Card

The 56k DDS CO card provides the interface between a Telco Central Office copper 4-wire DDS line and the fiber optic cable. It may also be used to extend a Telco demarcation point over fiber with the capability to be line power by a 12mA simplex sealing current. The 56KkCO card detects DC polarity reversals that occur between the send and receive pairs (remote loopback testing by Telco central office) and transmits this information to the Sub card.

56k DDS Sub Side Card

The 56k DDS Sub card provides the interface between the subscriber equipment (NIU or CSU/DSU) copper 4-wire DDS line and the fiber optic cable. The Sub card injects sealing current (18mA maximum) on the send and receive pairs. the DC source voltage is 2V less than the voltage connected to the power input terminal. If the CO card signals loopback, the Sub card reverses the polarity of the sealing current injected into the 4-wire send and receive pairs.

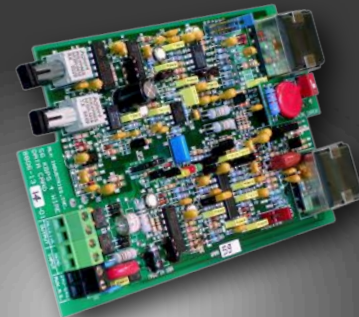

4 Wire 56k DDS Interface, 4RU Fiber Optic Link System ®

Contents

Description	1
General Safety Practices	2
Special Handling Requirements	3
Application	4
Installation	5
Troubleshooting	7
Order Information	7
General Specifications	8
Warranty	9
Contact Information	9

Compliance Information

The RLH 56k DDS Fiber Optic Link System is compliant with the following industry standards:

- **NEBS Level 3**
- **FCC PART-15**
- **FCC PART-68B**
- **IEEE-80 IEEE-367**
- **IEEE-487**
- **IEEE-1590**
- **IEEE-1615**
- **Motorola R56**
- **BR 876-310-100 BT (Telcordia)**
- **Bellcore SR-3966**
- **GR-1089**
- **GR-63**

Specifications subject to change without notice.

General Safety Practices

The equipment discussed in this document may require tools designed for the purpose being described. RLH recommends that service personnel be familiar with the correct handling and use of any installation equipment used, and follow all safety precautions including the use of protective personal equipment as required.

Caution - Severe Shock Hazard

- Never install during a lightning storm or where unsafe high voltages are present.
- Active phone lines may carry high DC voltages. Use caution when handling copper wiring.

Special Handling Requirements

Be careful when handling electronic components

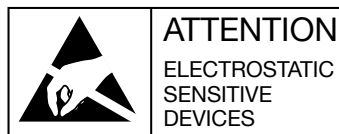

- This product contains static sensitive components.
- Handle the cards at their edges only.
- Follow proper electrostatic discharge procedures.

This card utilizes circuitry that can be damaged by static electricity. When transporting the card, carry it in an ESD safe container such as the antistatic bag provided with the card. Before handling cards, discharge yourself of static electricity by physical bodily contact with earth ground. When handling cards, hold by outer edges and avoid touching circuitry. Failure to follow ESD precautions may cause serious damage to the card and prevent proper operation.

Warning

The intra-building port(s) of the equipment or subassembly is suitable for connection to intrabuilding or unexposed wiring or cabling only. The intra-building port(s) of the equipment **MUST NOT** be metallically connected to interfaces that connect to the OSP or its wiring. These interfaces are designed for use as intra-building interfaces only (Type 4 ports as described in GR-1089-CORE, Issue 4) and require isolation from the exposed OSP cabling. The addition of Primary Protectors is not sufficient protection in order to connect these interfaces metallically to OSP wiring.

Guidelines for handling terminated fiber cable

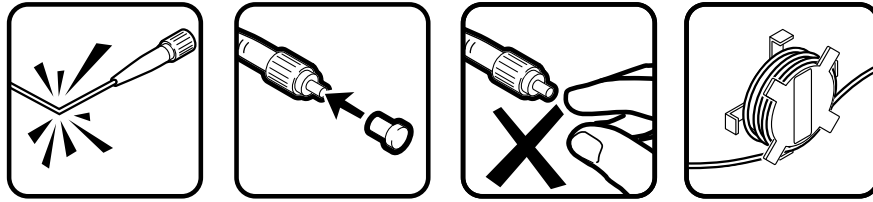

- Do not bend fiber cable sharply. Use gradual and smooth bends to avoid damaging glass fiber.
- Keep dust caps on fiber optic connectors at all times when disconnected.
- Do not remove dust caps from unused fiber.
- Keep fiber ends and fiber connectors clean and free from dust, dirt and debris. Contamination will cause signal loss.
- Do not touch fiber ends.
- Store excess fiber on housing spools or fiber spools at site

Applications

Telecommunication equipment in high voltage areas can be at risk due to Ground Potential Rise (GPR). A copper telephone line referenced to a remote ground can become a path for high current during a ground fault. Placement of all-dielectric fiber optic cable (instead of copper wire) from outside the high voltage area eliminates the safety hazard to personnel and equipment by removing the telephone remote ground. Standard 3-element gas tube copper protection is recommended at the 300V point for proper installation.

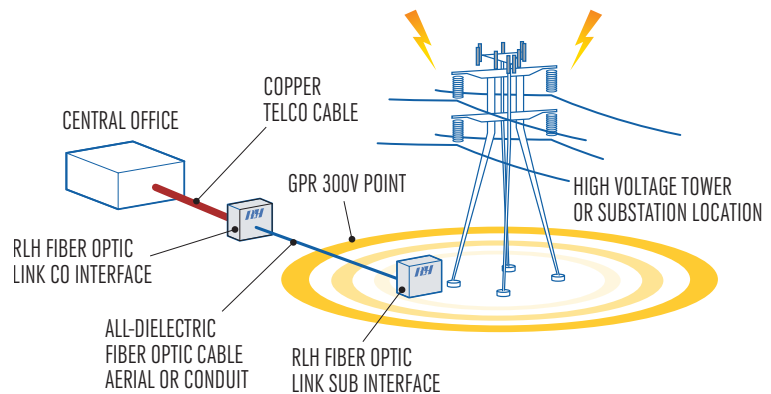

Note: In order to maintain high voltage isolation, Fiber Optic Link CO and Sub cards must be powered from separate isolated power sources.

Typical Application

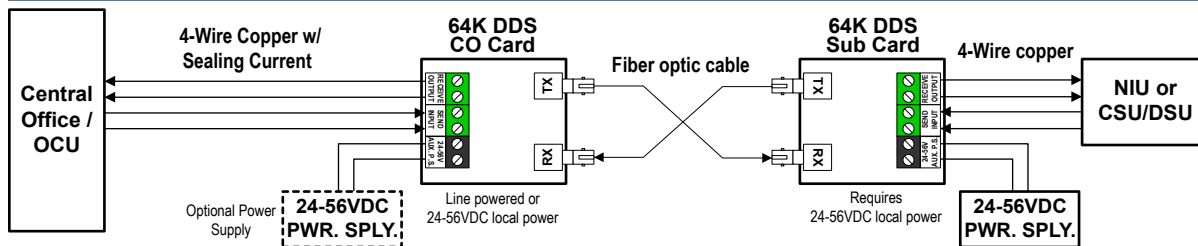

Fig. 1 - 56k DDS System Diagram

CO Card Powering

The 56k CO card is typically line powered by a minimum 12mA sealing current from the send and receive Telco pairs. The CO Card can also be locally powered by an isolated power source connected to the AUX P.S. terminal (24-56VDC). Battery polarity reversal remote testing may not be possible when the CO Cards are locally powered.

Note: For line power operation the Sealing Current Switch S1 on the CO Card must be in the OFF position. Set the switch to ON when the CO Card is locally powered through the AUX P.S. DC power input terminal.

Sub Card Powering

The 56k Sub Card operates from a 24-56VDC local source at 42mA maximum connected to the AUX P.S. terminal.

Note: In order to maintain high voltage isolation, Fiber Optic Link CO and Sub cards must be powered from separate isolated power sources.

Line Powering

When a DDS or Total Reach® NIU is placed at the CO side of the system, it must provide span through line power to the 56k CO fiber interface card. The 56k CO card can be line powered via 12mA sealing current on the line. When line power is available, no external or local power is required to operate the CO fiber card. An active DDS line with sealing current, connected to the fiber interface card should measure 19-20.4VDC between transmit and receive pairs with a maximum of 50mA. If voltage is not present, verify the NIU model number with the table below or contact RLH to ensure span through power capability.

Note: The 56k Sub card can provide line power to the Westell DDI 5740I3 T200 DDS remote NIU

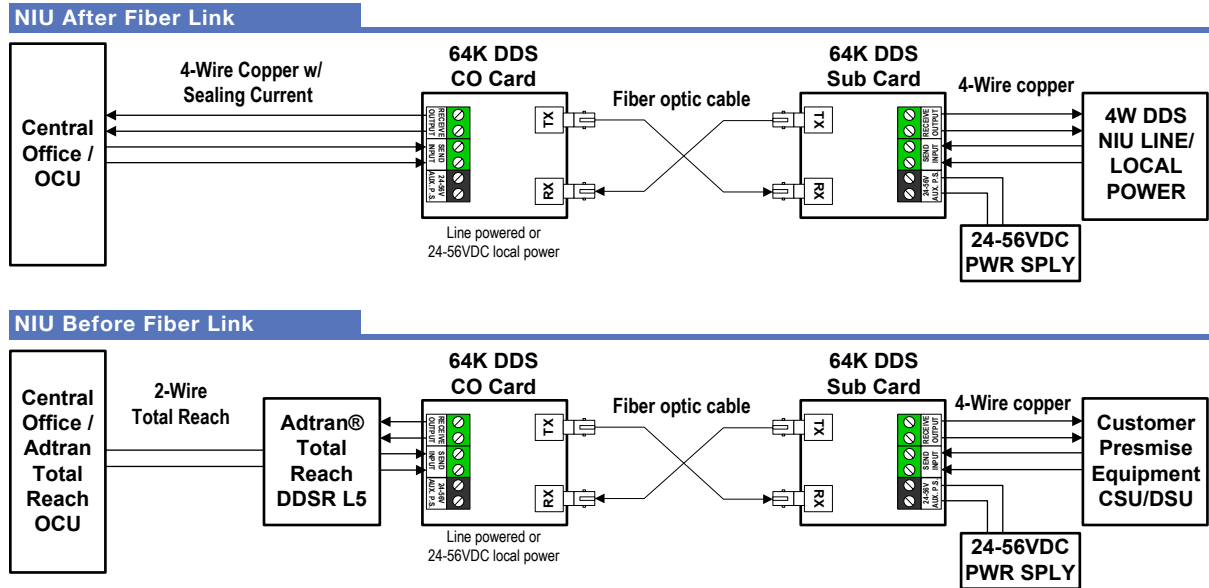

NIU

Configurations

NIU Information

Adtran Total Reach DDS Span Through Power NIUs			
Manufacturer	Part Number	Description and Mat. ID	CLEI Code
Adtran	I292023L5	T200 TRDDS-R	D4OIKTU8AA
Adtran	I292021L5	T200 TRDDS-R	D4OIKXU8AA

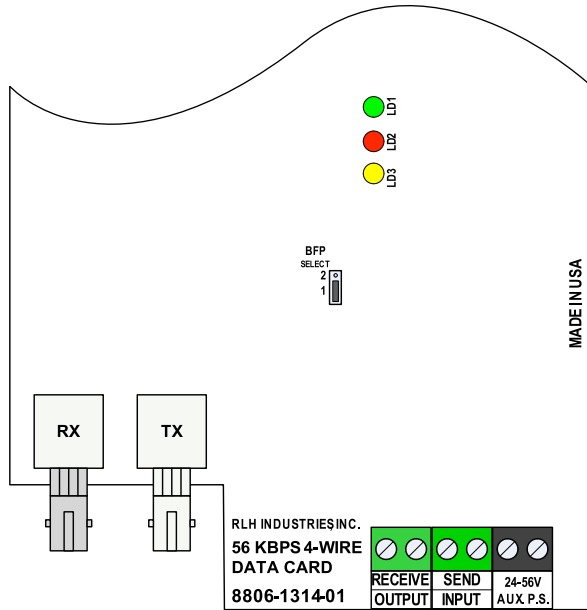

Table 2

LED	Color	ON	OFF
LD1	Green	Signal Received at copper input	Low level or no signal received at copper input
LD2	Red	Copper input signal overload	Normal copper input signal level
LD3	Yellow	Battery polarity reversal detected	Normal battery polarity

Card LED Description and Connectors

Installation

After unpacking the card, immediately inspect it for shipping damage. If damage is discovered file a claim immediately with the carrier, then contact RLH customer service.

Connect fiber optic cable

Cards are equipped with two either ST or SC type optical connectors. The transmitter is marked "TX", and the receiver is marked "RX". Be sure the transmitter is connected to the receiver on opposite end of fiber, i.e., if fiber #1 is connected to the TX on the CO Card, fiber #1 must be connected to the RX on the Sub Card. Fiber cable should be routed loosely avoiding tight bends.

Connect Copper Send and Receive pairs

The copper send and receive pairs connect to the green SEND/INPUT and RECEIVE/OUTPUT screw-down terminals on the 56k Card. The receive pair connects to the OUTPUT terminal (signal comes out of card). The send pair connects to the INPUT terminal (signal goes into card). Fiber Optic Link 56k CO Cards are designed to operate on standard 56k DDS lines that are current limited to 50mA maximum.

Connect and verify Power

Connect a 24-56V DC 15-42mA power source to the black screw-down terminal on the Card labeled 24-54VAUX. P.S.. The power input terminal is not polarity sensitive. If line power is available no local power connection is required for the CO card. The Sub card is always locally powered by an isolated power supply.

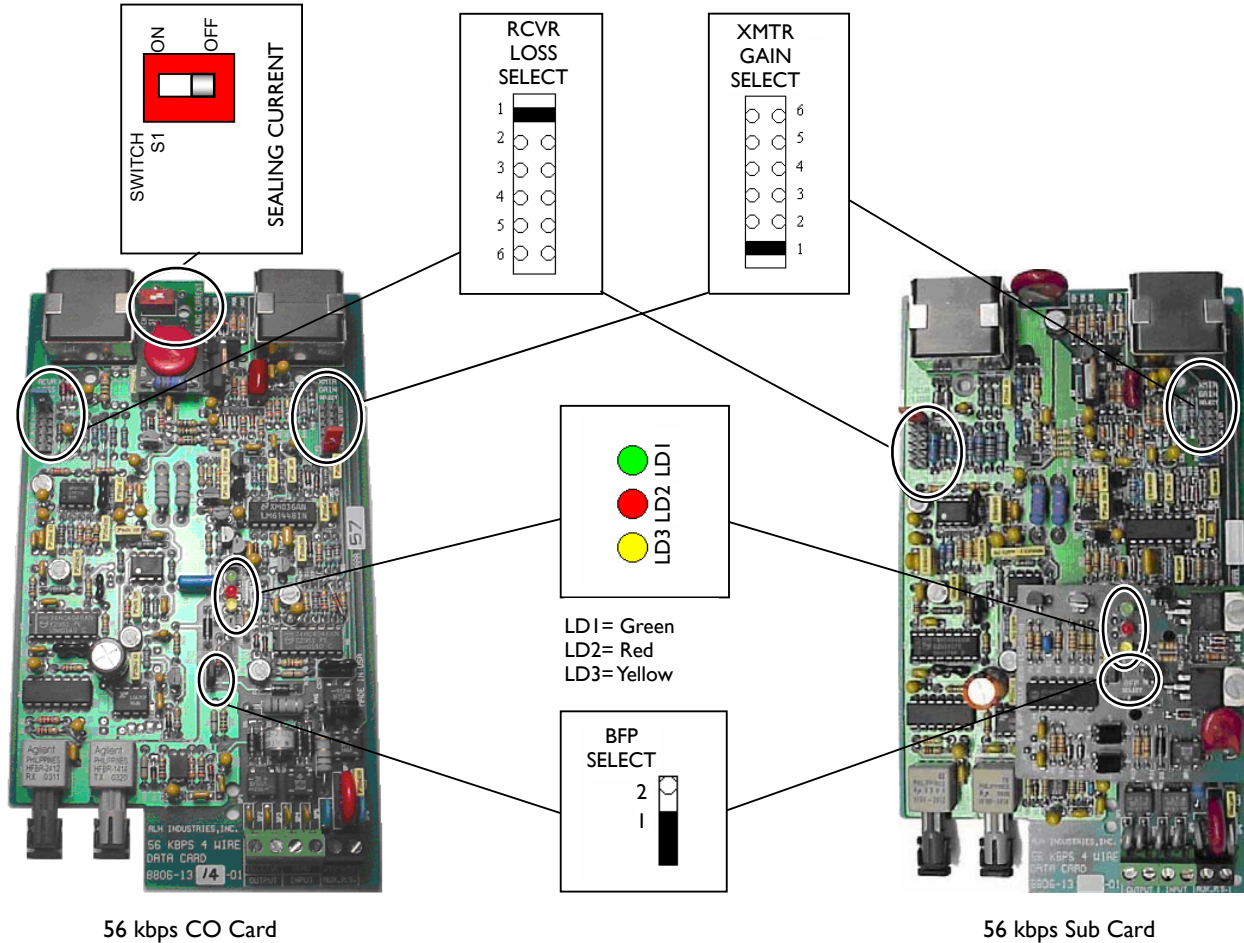

Adjustments to Factory Settings

Set 56k system Level

Note: 56k signals must be present at copper input terminal.

The optical transmit levels for the CO and Sub 56k cards set by the XMTR GAIN SELECT jumper. This is done by observing the green LD1 and red LD2 L.E.D.s to indicate the optimum setting. Gain is set in 6dB increments by selecting the highest numbered position that **not** turn on the red overload L.E.D., but **will** turn on the green transmit L.E.D.

Note: If the red L.E.D. is on, the green L.E.D. will also be on. If the green L.E.D. is not on, jump to a higher number position until the red L.E.D. is on, then set the jumper to the next lower numbered position.

After the gain is set, proceed to the far end card and set the RCVR LOSS SELECT jumper to the same number position as the XMTR GAIN SELECT jumper, e.g., if the GAIN jumper on the 56k Card is set to position 3, then the LOSS jumper on the opposite card must be set to position 3. Repeat in opposite direction.

BFP Jumper setting

The BFP (Battery Feed Polarity) Jumper on the CO Card provides polarity matching with the Telco Central Office Span Line power feed. The BFP jumper has 2 positions. It should be set to the position that keeps the Yellow L.E.D. OFF during normal operation. The Yellow L.E.D. should be ON only during a polarity reversal Loopback test. If the Yellow L.E.D. on the CO Card is ON, the Yellow LED on the Sub Card should also be ON and the Sub Card power feed should be reversed. Change position of the Sub BFP Jumper if the Subscriber Equipment is in loopback mode and the Central Office is not or the Subscriber equipment is not in loopback mode and the Central Office is in loopback mode.

Note: BFP Jumpers are factory installed at position 1.

CO Card Sealing Current Switch

The Sealing Current ON/OFF Switch is located only on the CO Card. Normally, it should be in the OFF position if the CO Card is line powered. Set the switch to ON when the CO Card is locally powered through the AUX P.S. input terminal.

Troubleshooting

If trouble is encountered, verify all installer connections, signal and voltage levels. If trouble persists, replace the unit and retest. If technical assistance is required, contact RLH Industries, Inc. Technical support department.

Ordering Information

RLH Fiber Optic Link products are available directly through RLH Industries, Inc. or its distributors nationwide. Please call RLH customer service for ordering assistance.

Each Fiber Optic Link card is identified with the part number.

Fiber Type	56k DDS CO Card		56k DDS Sub Card	
	Part Number	CLEI Code	Part Number	CLEI Code
Multimode ST *	8806-1314-01	NPIFCH01AA	8806-1324-01	NPIFDH01AA
Multimode SC *	8805-1314-01	–	8805-1324-01	–
Single-mode ST	8806-1318-01	NPIFCE01AA	8806-1328-01	NPIFDE01AA
Single-mode ST (Long Haul)	8806-1318-01LH	–	8806-1328-01LH	–
Single-mode SC	8805-1318-01	–	8805-1328-01	–
Single-mode SC (Long Haul)	8805-1318-01LH	–	8805-1328-01LH	–

- ▶ * 62.5µm multimode fiber compatibility is standard, add **-50** to part number for 50µm fiber compatibility
- ▶ Please contact your RLH sales representative for pricing and availability

General Specifications

Transmission method	Frequency modulated light via two optical fibers		
	Multimode	850nm	Tx level: -26dB +/- 1dB
	Single-mode	1310nm	Tx level: -27dB +/- 1dB
	Single-mode Long Haul	1310nm	Tx level: -12dB +/- 2dB
Maximum Fiber Loss / Distance	Multimode	8dB / 1.2 miles (2 km)	
	Single-mode	8dB / 9 miles (15 km)	
	Single-mode Long Haul	26dB* / 31 mi. (50 km)	
	*Note: Distances equated using industry standard fiber and connector attenuation of 3dB/Km. Fiber condition, splices and connectors may affect actual range.		
Fiber Type	Multimode	62.5/125µm, 50/125µm	
	Single-mode	8-9/125µm	
Fiber Connectors	ST or SC		
Temperature Limits	-40°F to +158°F (-40°C to +70°C)		
Humidity	95% non-condensing		
Bandwidth	1kHz to 300kHz		
Signal to Noise	>40dB for line attenuation up to 30dB at 28kHz		
Digital Data Type	Bipolar AMI digital data stream		
Data Rates	Analog	Minimum 19.2 kbps; Maximum: 64 kbps	
	DDS	4.8 kbps, 9.6 kbps, 19.2 kbps, 56 kbps, 64 kbps	
BER	<10 ⁻⁹		
Transmit Level (Loss Select at position 1)	3V P-P Nominal at 20°C (68°F)		
Insertion Loss	0dB +/- 1dB in each direction		
Surge Protection	PTC thermistors, gas tube, zener diodes, and MOVs		
Power Requirements	CO Card: Span power 19-20.4VDC, 12mA minimum, 50mA maximum		
	Aux. power 24-56VDC 12mA minimum. CO Card limits current to 15mA		
	Sub Card: Aux. power 24-56VDC, 20-42mA		
Powering Method	CO Card: Line power simplex on Send and Receive pairs, or a Local isolated DC power source connected to AUX. P.S. input.		
	Sub Card: Local isolated DC power source connected to AUX. P.S. input.		

Warranty

RLH is recognized throughout the U.S. and offers the only **UNCONDITIONAL LIFETIME WARRANTY** in the telecommunications industry. We are very proud of our warranty which simply states that our Fiber Optic Link Assemblies are warranted to be free of defects in material and workmanship for the **LIFE OF THE PRODUCT**.

We can offer this warranty because:

- We believe our customers shouldn't have to incur additional costs due to failure or damage
- We engineer and manufacture our Fiber Optic Links in the USA, with total confidence in our quality
- We understand how safety and reliability impact the total cost of ownership
- We know that customer support extends beyond the initial sale, so **we stand behind our products**

RLH will replace any product, or part thereof, that fails **FOR ANY REASON**, provided the defective part is returned to RLH Freight prepaid. This warranty is **UNCONDITIONAL** and valid even when RLH Fiber Optic Link Assemblies have been abused or mishandled, where unauthorized repairs have been attempted or performed, or product has been damaged as a result of a natural disaster. Compare this warranty to our competitors and see how our warranty will reduce your costs and simplify your maintenance activities.

To make a warranty claim, or schedule repair or replacement of your RLH product, please contact us for an RMA number. You will be promptly assisted by one of our warranty specialists. All returns must have an RMA number before we can receive any items.

Technical Support

Normal technical support: (Mon - Fri 6am - 6pm PST)	Local (714) 532-1672 Toll Free (800) 877-1672 Toll Free (866) DO-FIBER
24/7 Technical support:	(714) 396-8982 (714) 457-5740

Contact Information

Corporate Headquarters:	RLH Industries, Inc. 936 N. Main Street Orange, CA 92867 USA
Phone:	Local (714) 532-1672 Toll Free (800) 877-1672 Toll Free (866) DO-FIBER
Fax:	(714) 532-1885
Email:	info@fiberopticlink.com
Web site:	www.fiberopticlink.com

RLH FIBER OPTIC LINK

RLH Industries, Inc. The Leader in Fiber Optic Telecom Isolation Technology

LIFETIME

UNCONDITIONAL WARRANTY

RLH INDUSTRIES, INC. FIBER OPTIC LINK assemblies are warranted to be free of defects in materials and workmanship for the life of the product. This lifetime warranty is effective for RLH products sold from February 2, 1988, to the present, with the exception of fiber optic cable assemblies which are warranted only to be free of defects in manufacturing and batteries, which carry a 5-year unconditional replacement warranty.

RLH Industries, Inc. will repair or replace any product, or part thereof, that fails for any reason, provided the defective part is returned to RLH, freight prepaid.

This warranty is **UNCONDITIONAL** and is valid even when RLH Fiber Optic Link assemblies have been abused or mishandled, where unauthorized repairs have been attempted or performed, or product has been damaged as a result of a natural disaster.

Authorized by:



J. RANDALL MEARS, Vice President, Engineering



RLH Industries, Inc.
936 N. Main Street, Orange, CA 92867 USA
T: (714) 532-1672
F: (714) 532-1885

Please contact your RLH sales representative for pricing and delivery information.

Specifications subject to change without notice.