

## Ethernet Over Fiber 4RU Plug-in Card

10/100 ETHERNET

### Description

The RLH Fiber Optic Link 10/100 Ethernet Interface Card converts a copper 10Base-T or 100Base-TX to a fiber optic 100Base-FX transmission signal of either multimode or single-mode. The cards transmit the data signals over fiber optic cable, allow for network extension over long distances, and provide electrical isolation between both ends of the network.

The Ethernet over fiber card may be used as a system, with a card at each end, or the fiber optic cable may be connected directly to any 100Base-FX device. The card includes Link Fault Passthrough (LFP) mode with an LED indicator for link loss failure that allows for rapid fault isolation.

This hardened, rugged system is covered by our **Exclusive Unconditional Lifetime Warranty**.

**Note:** The cards listed in this document replace all other models. See the ordering section for part number information.

### Key Features

- Ideal for critical, high voltage, remote or un-manned locations that must remain operating 24/7/365
- Compatibility with IEEE 802.3 10 Base-T UTP, 100Base-TX, and 100Base-FX Devices
- RJ45 UTP port with 10//100 auto-negotiation
- Extends network span up to 1.2 miles (2km) on multimode and up to 74 miles (120km) on single-mode fiber
- Convenient LED status indicators
- Link alarm function for status monitoring
- Dual and Single (bi-directional) fiber models available
- Environmentally hardened to operate in -40°F to +158°F (-40°C to +70°C) environments
- Standard RLH 4RU form factor
- Covered by our **Exclusive Unconditional Lifetime Warranty**



RLH 10/100 Ethernet Over Fiber Card

ETHERNET  
OVER FIBER

### Contents

Description	1
Standard Features	1
General Safety Practices	2
Applications	3
Acronyms	4
Installation	4
Front Panel Connections	3
DIP Switch Settings	5
Troubleshooting	6
LED Indicators	6
Ordering Information	7
Specifications	8
Warranty	9
Technical Support	9

Specifications subject to change without notice.

## General Safety Practices

The equipment discussed in this document may require tools designed for the purpose being described. RLH recommends that service personnel be familiar with the correct handling and use of any installation equipment used, and follow all safety precautions including the use of protective personal equipment as required.

### Caution - Severe Shock Hazard

- Never install during a lightning storm or where unsafe high voltages are present.
- Use caution when handling copper wiring and follow appropriate safety regulations.

## Special handling requirements

### Be careful when handling electronic components

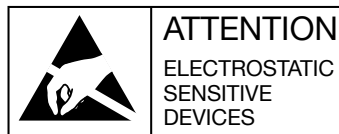

- This product contains static sensitive components.
- Handle Fiber Optic Link cards at their edges only.
- Follow proper electrostatic discharge procedures.

This card utilizes circuitry that can be damaged by static electricity. When transporting the card, carry it in an ESD safe container such as the antistatic bag provided with the card. Before handling cards, discharge yourself of static electricity by physical bodily contact with earth ground. When handling cards, hold by outer edges and avoid touching circuitry. Failure to follow ESD precautions may cause serious damage to the card and prevent proper operation.

### Guidelines for handling terminated fiber cable

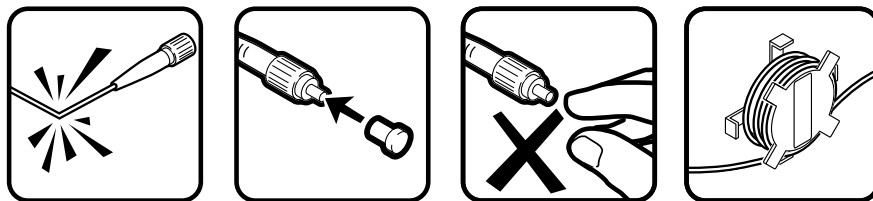

- Do not bend fiber cable sharply. Use gradual and smooth bends to avoid damaging glass fiber.
- Keep dust caps on fiber optic connectors at all times when disconnected.
- Do not remove dust caps from unused fiber.
- Keep fiber ends and fiber connectors clean and free from dust, dirt and debris. Contamination will cause signal loss.
- Do not touch fiber ends.
- Store excess fiber on housing spools or fiber spools at site

# Applications

Network equipment in high voltage areas can be at risk due to Ground Potential Rise (GPR). A copper network cable referenced to a remote ground can become a path for high voltages during a ground fault. Placement of all-dielectric fiber optic cable (instead of copper) completely eliminates the presence of a remote ground, which dramatically increases safety of personnel and reliability of equipment. By utilizing fiber optic cable, the Ethernet over fiber card provides absolute electrical isolation between both ends of the network.

Copper twisted pair Ethernet is limited to 100m/328ft without extenders. Using fiber optic cable provides long distance service (up to 120km/74mi.) without any additional equipment. It is immune to EMI/RF interference, ground loops, and high voltage surges from lightning or ground faults, and is ideal in electrically noisy environments such as near large power sources, electrical motors, and radio communications equipment.

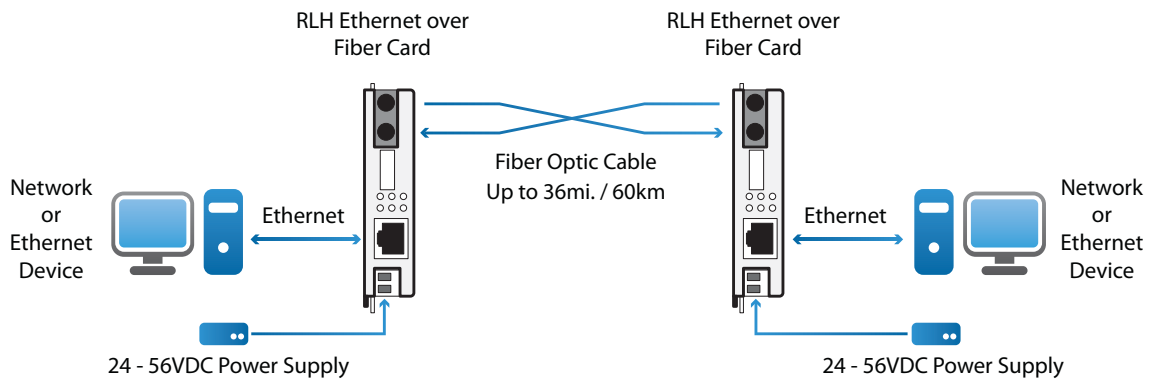

**Ethernet System Diagram**

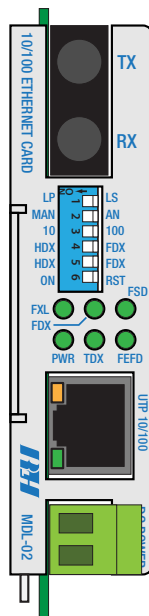

**Ethernet Over Fiber Card Front Panel**

# Acronyms

Commonly used acronyms and abbreviations

Acronym/Abbreviation	Description
RU	Rack Unit (EIA)
UTP	Unshielded Twisted Pair (commonly used in Ethernet networks)
TP	Twisted Pair (same as UTP)
LFP	Link Fault Passthrough
TX	Transmit
RX	Receive
MAN	Manual
AN	Auto Negotiating
HDX	Half Duplex
FDX	Full Duplex
LS	Link Fault Passthrough Suspend
LP	Link Fault Passthrough Pass

## Installation

Prior to installation:

- Check for shipping damage
- Check the contents to ensure correct model and fiber type
- Have a clean, dry installation environment ready

Required for installation:

- 24-56VDC (3W minimum) power source
- RLH card housing

Measure the DC voltage of the source power to ensure that it is 24-56VDC (3W minimum). All electrical and fiber optic connection are made directly onto the card. The Ethernet over fiber card is designed to be installed into any RLH card housing.

### Connect fiber optic cable

Multimode and single-mode Ethernet cards are equipped with either two ST or SC female optical connectors, or a single bi-directional connector (SC only). Connect fibers to the Transmit (TX) and Receive (RX) optical connectors. The other end of the fiber may be connected to another Ethernet card or any 100BASE-FX Ethernet device. For bi-directional, single fiber models, there is only one SC connector used for transmitting and receiving.

Fiber cable should always be routed loosely avoiding tight bends.

### Connect Ethernet cable

The 10/100Base-T copper connection is made via the RJ45 port located on the front of the card with. A manual crossover switch is located on the front panel (see figure 1). When connecting to a hub or switch, set to "straight through" (factory setting). When connecting to a workstation, set to "crossover".

## Connect Power

Connect a 24-56VDC (200mA minimum) power source to the screw-down terminal on the Ethernet card. The power input is not polarity sensitive. The terminal unplugs from the card to make wiring easier.

## DIP Switch Settings

The front panel DIP switches may be set for optional modes. The factory default is **ON** for all switches.

### Ethernet DIP Switch Settings

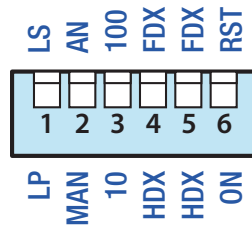

Switch	Description	Setting	Function
1	Link Fault Pass-through	LP	LFP enabled (Default)
		LS	LFP disabled
2	TP Port Mode	AN	TP is auto negotiating (Default)
		MAN	Force TP at 10M or half duplex
3	TP Port Speed	100	TP at 100M (Default)
		10	TP at 10M when TP Port Mode at Force
4	TP Port Duplex	FDX	TP at full duplex (Default)
		HDX	TP at half duplex when Port Mode at Force
5	Fiber Port Duplex	FDX	Fiber port at full duplex (Default)
		HDX	Fiber port at half duplex
6	Reset	ON	Power on (Default)
		RST	Recycle power (See note)

- ▶ After changing any of the DIP switches, recycle the power to the card by flipping switch 6 (Reset) from ON to RST then back to ON.
- ▶ DIP switch 2 must be set to MAN when switches 3 and 4 are set to 10 and HDX respectively.

**Note:** Connecting an auto-negotiating device to a non-auto-negotiating device may result in an unpredictable port setting with poor link performance. When operating in Manual mode, both mating ports must be set to the same data rate and duplex mode.

# Troubleshooting

If trouble is encountered, verify all copper and fiber connections and settings. If any of the DIP switches were changed, you must recycle the power by flipping switch 6 to RST (Reset) and ON again to enable the settings. Refer to the LED Indicators on the front panel, they show availability of power, modes of operation, and data being received by the fiber and TP port.

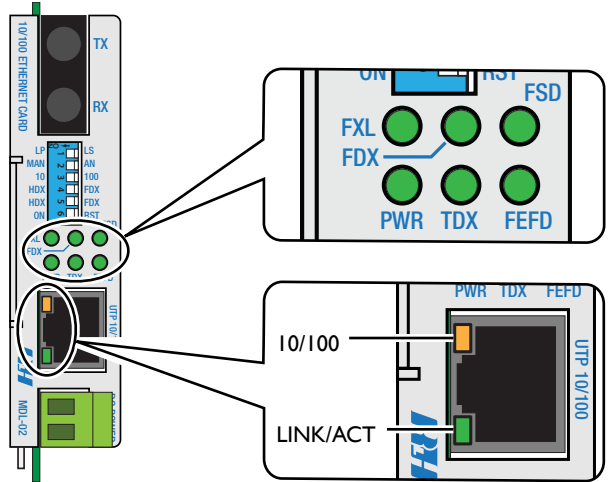

Indicator	Color	LED	Description
FXL	GRN	ON	Fiber port link OK
		Blinking	Fiber port link OK and activity is present
		OFF	Fiber port link fail
FDX	GRN	ON	Fiber port at full duplex
		OFF	Fiber port at half duplex
		Blinking	Fiber port at half duplex and collisions occurring
FSD	GRN	ON	Fiber signal detected
		OFF	Fiber disconnected
FEFD	GRN	OFF	Normal operation
		Blinking	Far end fault detected
TDX	GRN	ON	TP port at full duplex
		OFF	TP port at half duplex
		Blinking	TP port at half duplex and collisions occurring
PWR	GRN	ON	Card power is ON
		OFF	Card power is OFF
10/100	ORG	ON	TP port speed is 100M
		OFF	TP port speed is 10M
LINK/ACT	GRN	ON	TP port link OK
		Blinking	TP port link OK and activity is present
		OFF	TP port link not present

If trouble persists, replace the unit and retest. If technical assistance is required, contact the RLH technical support department:

800-877-1672 (6 am to 6 pm- PST),  
 or call our 24/7 Technical/Customer Service: (714) 366-2503 or (714) 457-5740

# Ordering Information

EF4 - XXXXXX - 02

Configuration Code

Code	Multimode	Single Mode	Single Fiber Bi-Directional	Dual Fiber	SC Connector	ST Connector	FC Connector	2km/1.25mi. range	20km/12.4mi. range	40km/24.9 mi. range	60km/37 mi. range	120km/74 mi. range	FXO/CO Side	FXS/Sub Side	Either Side
MBSCC *	●		●		●			●					●		
MBSCS *	●		●		●			●						●	
MMSCD *	●			●	●			●							●
MMSTD *	●			●		●		●							●
MMFCD *	●			●			●	●							●
S2SCC		●	●		●				●				●		
S2SCS		●	●		●				●					●	
S3SCC		●	●		●					●			●		
S3SCS		●	●		●					●				●	
S2STC		●	●			●			●				●		
S2STS		●	●			●			●					●	
S3STC		●	●			●				●			●		
S3STS		●	●			●				●				●	
S2FCC		●	●				●		●				●		
S2FCS		●	●				●		●					●	
S3FCC		●	●				●			●			●		
S3FCS		●	●				●			●				●	
S1SCD		●		●	●				●						●
S4SCD		●		●	●						●				●
S6SCD		●		●	●							●			●
S1STD		●		●		●			●						●
S4STD		●		●		●					●				●
S6STD		●		●		●						●			●
S1FCD		●		●			●		●						●
S4FCD		●		●			●				●				●
S6FCD		●		●			●					●			●

- ▶ \* 62.5µm multimode fiber compatibility is standard, add **-50** to part number for 50µm fiber compatibility
- ▶ Bi-directional single fiber systems require a FXO/CO side and FXS/Sub side unit
- ▶ Please contact your RLH sales representative for pricing and delivery information

## General Specifications

<b>Protocols</b>	100BASE-FX, 10BASE-T, or 100BASE-TX			
<b>Copper Connector</b>	RJ45 UTP			
<b>Copper Distance</b>	100m / 328 feet			
<b>Fiber Connector</b>	ST, SC or FC			
	Dual fiber or single fiber (bi-directional) connectors			
	<b>Fiber Type</b>	<b>Multimode</b>		<b>Single-mode</b>
	<b>Wavelength TX/RX (nm)</b>	1310	1310	1310
	<b>Distance</b>	2km / 1.2 mi.	20km / 12 mi.	60km / 36 mi. 120km / 74 mi.
<b>Dual Fiber Optics</b>	<b>Min. TX PWR (dBm)</b>	-18	-15	-6 0
	<b>Max. TX PWR (dBm)</b>	-10	-8	-3 +5
	<b>RX Sensitivity (dBm)</b>	-31	-34	-34 -34
	<b>Link Loss Budget (dBm)</b>	13	19	28 34
	<b>Fiber Type</b>	<b>Multimode</b>		<b>Single-mode</b>
	<b>Wavelength (nm)</b>	1550	1550	1550 -
	<b>Distance</b>	2km / 1.2 mi.	20km / 12 mi.	40km / 25 mi. -
<b>Single Fiber Optics (Bi-directional)</b>	<b>Min. TX PWR (dBm)</b>	2-17	-14	-9 -
	<b>Max. TX PWR (dBm)</b>	-10	-8	-5 -
	<b>RX Sensitivity (dBm)</b>	-31	-34	-34 -
	<b>Link Loss Budget (dBm)</b>	14	20	25 -
	<b>FXL (Fiber)</b>	Fiber port link - ON: link OK, OFF: link fail, Blink: activity		
	<b>FDX (Fiber)</b>	Fiber port full duplex - ON: full, OFF: half, Blink: half & collisions		
	<b>FSD</b>	Fiber signal detect - ON: signal detected, OFF: fiber disconnected		
<b>LED Indicators</b>	<b>FEFD</b>	Far end fault detection - OFF: normal operation, Blinking: far end fault detected		
	<b>TDX</b>	TP port full duplex - ON: full, OFF: half, Blink: half & collisions		
	<b>PWR</b>	Power - ON: power applied, OFF: no power		
	<b>10/100</b>	TP port speed - ON: 100m, OFF: 10M		
	<b>LINK/ACT</b>	TP port link - ON: link OK, OFF: no link, Blink: activity		
<b>Power Input</b>	24~56VDC @ 3W			
<b>Dimensions</b>	7.0" x 4.0" x 1.0"			
<b>Temperature</b>	<b>Operating</b>	-40°F to +158°F (-40°C to +70°C)		
	<b>Storage</b>	-40°F to +176°F (-40°C to +80°C)		
<b>Humidity</b>	5~95% non-condensing			

## Warranty

RLH is recognized throughout the U.S. and offers the only **UNCONDITIONAL LIFETIME WARRANTY** in the telecommunications industry. We are very proud of our warranty which simply states that our Fiber Optic Link Assemblies are warranted to be free of defects in material and workmanship for the **LIFE OF THE PRODUCT**.

### We can offer this warranty because:

- We believe our customers shouldn't have to incur additional costs due to failure or damage
- We engineer and manufacture our Fiber Optic Links in the USA, with total confidence in our quality
- We understand how safety and reliability impact the total cost of ownership
- We know that customer support extends beyond the initial sale, so **we stand behind our products**

RLH will replace any product, or part thereof, that fails **FOR ANY REASON**, provided the defective part is returned to RLH Freight prepaid. This warranty is **UNCONDITIONAL** and valid even when RLH Fiber Optic Link Assemblies have been abused or mishandled, where unauthorized repairs have been attempted or performed, or product has been damaged as a result of a natural disaster. Compare this warranty to our competitors and see how our warranty will reduce your costs and simplify your maintenance activities.

**To make a warranty claim, or schedule repair or replacement of your RLH product, please contact us for an RMA number.** You will be promptly assisted by one of our warranty specialists. All returns must have an RMA number before we can receive any items.

## Technical Support

<b>Normal technical support:</b> (Mon - Fri 6am - 6pm PST)	Local (714) 532-1672 Toll Free (800) 877-1672 Toll Free (866) DO-FIBER
<b>24/7 Technical support:</b>	(714) 396-8982 (714) 457-5740

## Contact Information

<b>Corporate Headquarters:</b>	RLH Industries, Inc. 936 N. Main Street Orange, CA 92867 USA
<b>Phone:</b>	Local (714) 532-1672 Toll Free (800) 877-1672 Toll Free (866) DO-FIBER
<b>Fax:</b>	(714) 532-1885
<b>Email:</b>	info@fiberopticlink.com
<b>Web site:</b>	www.fiberopticlink.com



# RLH FIBER OPTIC LINK

RLH Industries, Inc., The Leader in Fiber Optic Telecom Isolation Technology

**LIFETIME**

## UNCONDITIONAL WARRANTY

RLH INDUSTRIES, INC. FIBER OPTIC LINK assemblies are warranted to be free of defects in materials and workmanship for the life of the product. This lifetime warranty is effective for RLH products sold from February 2, 1988, to the present, with the exception of fiber optic cable assemblies which are warranted only to be free of defects in manufacturing and batteries, which carry a 5-year unconditional replacement warranty.

RLH Industries, Inc. will repair or replace any product, or part thereof, that fails for any reason, provided the defective part is returned to RLH, freight prepaid.

This warranty is UNCONDITIONAL and is valid even when RLH Fiber Optic Link assemblies have been abused or mishandled, where unauthorized repairs have been attempted or performed, or product has been damaged as a result of a natural disaster.

Authorized by: J. Randall Mears  
J. RANDALL MEARS, Vice President, Engineering



RLH Industries, Inc.  
936 N. Main Street, Orange, CA 92867 USA  
T: (714) 532-1672  
F: (714) 532-1885

Please contact your RLH sales representative for pricing and delivery information.

Specifications subject to change without notice.