

Ethernet Over Fiber 4RU Plug-in Card

10/100/1000M ETHERNET

Introduction

The RLH 10/100/1000 Ethernet 4RU Interface Card converts a copper 10Base-T or 100/1000Base-TX to a 1000Base-SX/LX fiber optic transmission signal of either multimode or single-mode. The cards transmit the data signals over fiber optic cable which allow for network extension over long distances, and provide electrical isolation between both ends of the network.

The Ethernet over fiber card may be used as a system, with a card at each end, or the fiber optic cable may be connected directly to any 1000Base-SX/LX compatible device.

This hardened, rugged system is covered by our **Exclusive Unconditional Lifetime Warranty**.

Key Features

- Ideal for critical, high voltage, remote or un-manned locations that must remain operating 24/7/365
- Compatibility with IEEE 802.3/AB
- RJ45 UTP port with 10/100/1000 auto-negotiation
- Extends network span up to 1.2 miles (2km) on multimode and up to 74 miles (120km) on single-mode fiber
- Convenient LED status indicators
- Link alarm function for status monitoring
- Dual and Single (bi-directional) fiber models available
- Environmentally hardened to operate in -40°F to +158°F (-40°C to +70°C) environments
- Standard RLH 4RU form factor
- Covered by our **Exclusive Unconditional Lifetime Warranty**



RLH 10/100/1000 Ethernet over Fiber Card

ETHERNET OVER FIBER

Contents

Introduction	1
General Safety Practices	2
Special Handling Requirements	2
Acronyms	3
Applications	3
Installation	4
LED Indicators	5
DIP Switch Settings	5
Link Alarm	6
Ordering Information	6
General Specifications	7
Troubleshooting	8
Warranty	8
Technical Support	8

Specifications subject to change without notice.

General Safety Practices

Intended Audience

This guide is intended for use by knowledgeable telco/network installation, operation and repair personnel. Every effort has been made to ensure the accuracy of the information in this guide is accurate. However, due to constant product improvement, specifications and information contained in this document are subject to change without notice.

Conventions

Symbols for notes, attention, and caution are used throughout this manual to provide readers with additional information, advice when special attention is needed, and caution to prevent injury or equipment damage.

The equipment discussed in this document may require tools designed for the purpose being described. RLH recommends that service personnel be familiar with the correct handling and use of any installation equipment used, and follow all safety precautions including the use of protective personal equipment as required.

Caution - Severe Shock Hazard

- Never install during a lightning storm or where unsafe high voltages are present.
- Active phone lines may carry high DC voltages. Use caution when handling copper wiring.

Warning

The intra-building port(s) of the equipment or subassembly is suitable for connection to intrabuilding or unexposed wiring or cabling only. The intra-building port(s) of the equipment **MUST NOT** be metallically connected to interfaces that connect to the OSP or its wiring. These interfaces are designed for use as intra-building interfaces only (Type 4 ports as described in GR-1089-CORE, Issue 4) and require isolation from the exposed OSP cabling. The addition of Primary Protectors is not sufficient protection in order to connect these interfaces metallically to OSP wiring.

Special Handling Requirements

Be careful when handling electronic components

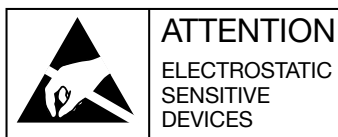

- This product contains static sensitive components.
- Handle Fiber Optic Link cards at their edges only.
- Follow proper electrostatic discharge procedures.

This card utilizes circuitry that can be damaged by static electricity. When transporting the card, carry it in an ESD safe container such as the antistatic bag provided with the card. Before handling cards, discharge yourself of static electricity by physical bodily contact with earth ground. When handling cards, hold by outer edges and avoid touching circuitry. Failure to follow ESD precautions may cause serious damage to the card and prevent proper operation.

Guidelines for handling terminated fiber cable

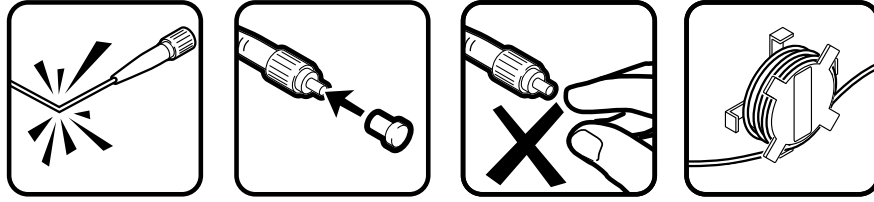

- Do not bend fiber cable sharply. Use gradual and smooth bends to avoid damaging glass fiber.
- Keep dust caps on fiber optic connectors at all times when disconnected.
- Do not remove dust caps from unused fiber.
- Keep fiber ends and fiber connectors clean and free from dust, dirt and debris. Contamination will cause signal loss.
- Do not touch fiber ends.
- Store excess fiber on housing spools or fiber spools at site

Acronyms

Commonly used acronyms and abbreviations

Acronym/Abbreviation	Description
UTP	Unshielded Twisted Pair (commonly used in Ethernet networks)
TP	Twisted Pair (same as UTP)
FO	Fiber Optic
TX	Transmit
RX	Receive
PWR	Power
GRN	Green
ORG	Orange

Applications

Network equipment in high voltage areas can be at risk due to Ground Potential Rise (GPR). A copper network cable referenced to a remote ground can become a path for high voltages during a ground fault. Placement of all-dielectric fiber optic cable (instead of copper) completely eliminates the presence of a remote ground, which dramatically increases safety of personnel and reliability of equipment. By utilizing fiber optic cable, the 10/100/1000 Ethernet over fiber card provides absolute electrical isolation between both ends of the network.

Copper twisted pair Ethernet is limited to 100m/328ft without extenders. Using fiber optic cable provides long distance service (up to 120km/74mi.) without any additional equipment. Fiber is immune to EMI/RF interference, ground loops, and high voltage surges from lightning or ground faults, and is ideal in electrically noisy environments such as near large power sources, electrical motors, and radio communications equipment.

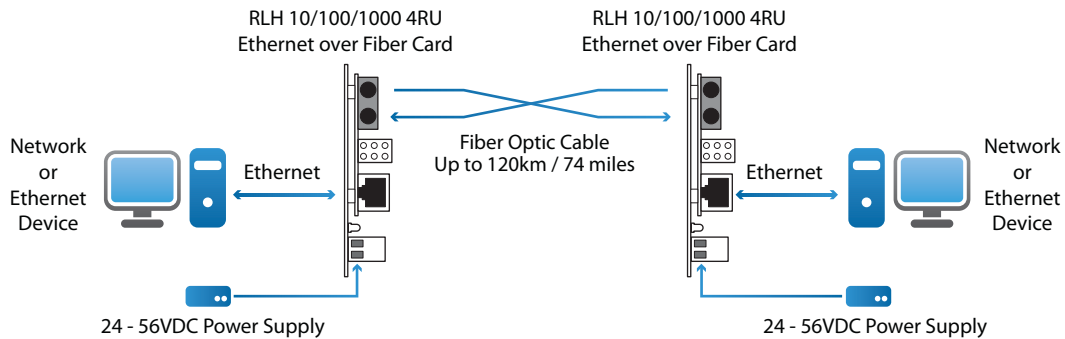

Typical Ethernet System Diagram

Installation

Prior to installation:

- Check for shipping damage
- Check the contents to ensure correct model and fiber type
- Have a clean, dry installation environment ready

Required for installation:

- 24-56VDC (3W minimum) power source
- RLH card housing

Measure the DC voltage of the source power to ensure that it is 24-56VDC (3W minimum). All electrical and fiber optic connection are made directly onto the card. The Ethernet over fiber card is designed to be installed into any RLH card housing.

Note: In order to maintain high voltage isolation, Fiber Optic Link CO and Sub cards must be powered from separate isolated power sources.

Connect fiber optic cable

Multimode and single-mode Ethernet cards are equipped with either two ST, SC or FC female optical connectors, or a single bi-directional connector (SC only). Connect fibers to the Transmit (TX) and Receive (RX) optical connectors. The other end of the fiber may be connected to another 10/100/1000 Ethernet card or any 1000SX/LX Ethernet device. For bi-directional, single fiber models, there is only one SC connector used for transmitting and receiving.

Note: Fiber cable should always be routed loosely avoiding tight bends.

Connect Ethernet cable

The 10/100/1000Base-T copper connection is made via the RJ45 port located on the front of the card with. The TP port is auto-negotiating and requires no special settings.

Connect Power

Connect a 24-56VDC (200mA minimum) power source to the screw-down terminal on the Ethernet card. The power input is not polarity sensitive. The terminal unplugs from the card to make wiring easier

LED Indicators

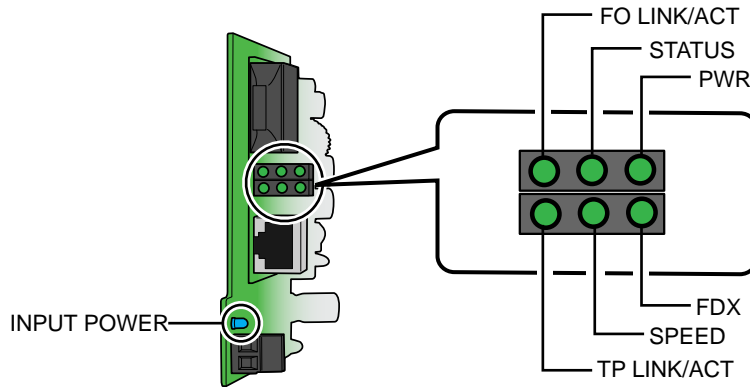

Indicator	Color	LED	Description
PWR	GRN	ON	Fiber/TP port power is OK
		OFF	Fiber/TP port power FAIL
TP LINK/ACT	GRN	ON	TP connection with remote device is good
		Blinking	TP traffic is present
FO LINK/ACT	GRN	ON	Fiber connection with remote device is good
		Blinking	Fiber optic traffic is present
FDX	GRN	ON	TP port is full duplex
		OFF	TP port is half duplex
SPEED	GRN	ON	TP port speed is 10M or no link is present
		OFF	TP port is speed is 100M
STATUS	ORG	ON	TP port is speed is 1000M
	GRN	ON	TP and Fiber link are up
	ORG	ON	TP and Fiber link are down

DIP Switch



Switch No.	Description	OFF	ON
1	TP Auto Negotiation	Disable	Enable
2	Manual TP Speed	10M	100M
3	Manual TP Speed	N/A	1000M
4	Duplex Mode	Half	Full
5	Flow Control	Disable	Enable
6	F/O Alarm	Force	Auto
7	Link Alarm	Disable	Enable
8	Transmission Mode	Store and Forward	Pass-through

Notes:

- Before changing TP Speed, Duplex Mode and Flow Control setting, set switch 1 to OFF.
- When manually setting TP speed to 10M or 100M, set switch 3 to OFF.
- 1000M throughput supports full duplex only.
- When switch 8 is ON, TP speed is forced to 1000M and full duplex and flow control are disabled.
- Power reset must be performed after changing any DIP switch setting.

Link Alarm

The link alarm feature allows users to easily identify and diagnose the link status for TP and fiber optic segments. When link alarm is enabled, TP and F/O ports will link up only when both TP and F/O segment linking conditions are good.

If either TP or F/O segment is down during operation, the other port will also shut down the link to alert users and avoid packet loss. When the link alarm is disabled, the TP and F/O port will link up based on their own segment linking condition. For example, if the F/O segment is down during operation, this device will not shut down the TP port link to the segment and vice versa.

Ordering Information

EG4 - XXXXX - 01

Configuration Code

Code	Multimode	Single Mode	Single Fiber Bi-Directional	Dual Fiber	SC Connector	ST Connector	FC Connector	2km/1.25mi. range	20km/12.4mi. range	40km/24.9 mi. range	60km/37 mi. range	120km/74 mi. range	FXO/CO Side	FXS/Sub Side	Either Side
MBSCC *	●		●		●			●					●		
MBSCS *	●		●		●			●						●	
MMSCD *	●			●	●			●							●
MMSTD *	●			●		●		●							●
MMFCD *	●			●			●	●							●
S2SCC		●	●		●			●					●		
S2SCS		●	●		●			●						●	
S3SCC		●	●		●					●			●		
S3SCS		●	●		●					●				●	
S2STC		●	●			●		●					●		
S2STS		●	●			●		●						●	
S3STC		●	●			●				●			●		
S3STS		●	●			●				●				●	
S2FCC		●	●				●	●					●		
S2FCS		●	●				●	●						●	
S3FCC		●	●				●			●			●		
S3FCS		●	●				●			●				●	
S1SCD		●		●	●			●							●
S4SCD		●		●	●						●				●
S6SCD		●		●	●							●			●
S1STD		●		●		●		●							●
S4STD		●		●		●					●				●
S6STD		●		●		●						●			●
S1FCD		●		●			●	●							●
S4FCD		●		●			●				●				●
S6FCD		●		●			●					●			●

- ▶ * 62.5µm multimode fiber compatibility is standard, add **-50** to part number for 50µm fiber compatibility
- ▶ Bi-directional single fiber systems require a FXO/CO side and FXS/Sub side unit
- ▶ Please contact your RLH sales representative for pricing and delivery information

General Specifications

Protocols	1000BASE-SX/LX, 10BASE-T, or 100/1000BASE-TX				
Copper Connector	RJ45 UTP				
Copper Distance	100m / 328 feet				
Fiber Connector	ST, SC OR FC				
	Dual fiber (ST, SC or FC), or single fiber (bi-directional, SC only) connectors				
Dual Fiber Optics	Fiber Type	Multimode		Single-mode	
	Wavelength TX/RX (nm)	1310	1310	1310	1310
	Distance	2km / 1.2 mi.	20km / 12 mi.	60km / 36 mi.	120km / 74 mi.
	Min. TX PWR (dBm)	-18	-15	-6	0
	Max. TX PWR (dBm)	-10	-8	-3	+5
	RX Sensitivity (dBm)	-31	-34	-34	-34
	Link Loss Budget (dBm)	13	19	28	34
	Single Fiber Optics (Bi-directional)	Fiber Type	Multimode		Single-mode
Wavelength (nm)		1550	1550	1550	1550
Distance		2km / 1.2 mi.	20km / 12 mi.	40km / 25 mi.	60km / 36 mi.
Min. TX PWR (dBm)		2-17	-14	-9	-5
Max. TX PWR (dBm)		-10	-8	-5	-3
RX Sensitivity (dBm)		-31	-34	-34	-34
Link Loss Budget (dBm)		14	20	25	29
LED Indicators		LINK/ACT	Fiber port link - Blink together: Link OK, Blink alternating: link fail		
	FX	Fiber signal - ON: fiber signal is OK, Blink: collisions			
	10/100/1000	TP port speed - ON: 1000m, OFF: 10/100M			
	FDX	TP port full duplex - ON: full duplex, OFF: half, Blink: collisions			
	PWR	Fiber/TP power - ON: power OK, OFF: no power			
	INPUT POWER	Card power - ON: power OK, OFF: no power			
Power Input	24~56VDC @ 3W				
Dimensions	7.0" x 4.0" x 1.0"				
Temperature	Operating	-40°F to +176°F (-40°C to +80°C)			
	Storage	-40°F to +194°F (-40°C to +90°C)			
Humidity	5~95% non-condensing				

Specifications subject to change without notice.

Troubleshooting

If trouble is encountered, verify all copper and fiber connections and settings. Refer to the LED Indicators at the front of the card. They show availability of power, modes of operation, and data being received by the fiber and TP port. If trouble persists, replace the unit and retest. If technical assistance is required, contact RLH Industries, Inc. technical support department:

800-877-1672 (6 am to 6 pm- PST),
or call our 24/7 Technical/Customer Service: (714) 366-2503 or (714) 457-5740

Warranty

RLH is recognized throughout the U.S. and offers the only **UNCONDITIONAL LIFETIME WARRANTY** in the telecommunications industry. We are very proud of our warranty which simply states that our Fiber Optic Link Assemblies are warranted to be free of defects in material and workmanship for the **LIFE OF THE PRODUCT**.

RLH will replace this product, or part thereof, if it fails FOR ANY REASON, provided the defective part is returned to RLH Freight prepaid. This warranty is UNCONDITIONAL and valid even when this product has been abused, mishandled, or damaged as a result of a natural disaster. This warranty will reduce your costs and simplify your maintenance activities. Not all RLH products are covered by this warranty.

To make a warranty claim, or schedule repair or replacement of your RLH product, please contact us for an RMA number. You will be promptly assisted by one of our warranty specialists. All returns must have an RMA number before we can receive any items.

Technical Support

Normal technical support hours (Mon - Fri 6am - 6pm PST)	Local (714) 532-1672 Toll Free (800) 877-1672 Toll Free (866) DO-FIBER
24/7 Technical support	(714) 396-8982 (714) 457-5740

Contact Information

Corporate Headquarters	RLH Industries, Inc. 936 N. Main Street Orange, CA 92867 USA
Phone	Local (714) 532-1672 Toll Free (800) 877-1672 Toll Free (866) DO-FIBER
Fax	(714) 532-1885
Email	info@fiberopticlink.com
Web site	www.fiberopticlink.com



RLH Industries, Inc.
936 N. Main Street, Orange, CA 92867 USA
T: (714) 532-1672
F: (714) 532-1885

Please contact your RLH sales representative for pricing and delivery information.

Specifications subject to change without notice.