

## Fiber Optic Link 4-Channel 4-20mA / 0-10VDC Analog System Description and Installation

Fiber Type	4-Ch 4-20mA / 0-10V Transmitter Card	4-Ch 4-20mA / 0-10V Receiver Card
Multimode ST	8806-1506-01	8806-1516-01
Multimode SC	8805-1506-01	8805-1516-01
Single-mode ST	8806-1526-01	8806-1536-01
Single-mode SC	8805-1526-01	8805-1536-01
Single-mode ST (Long Haul)	8806-1526-01LH	N/A
Single-mode SC (Long Haul)	8805-1526-01LH	N/A

Add "-12V" to the end of part number for 9-36VDC powering



### Description

The Fiber Optic Link 4-20mA / 0-10VDC analog system provides a transmission of up to four independent analog signals over one optical fiber.

**Analog Transmitter Card.** The Transmitter card provides the electrical-to-optical interface between four independent analog 4-20mA or 0-10VDC inputs and a fiber strand. Each channel can be selected for 4-20mA or 0-10V signal protocols. The card is locally powered from a 22-56VDC source. The Transmitter card provides a power LED indicator.

**Note:** The Transmitter can be modified for use with 0-5VDC or 0-20mA signals. Consult factory.

**Analog Receiver Card.** The Receiver Card provides the optical-to-electrical interface between a fiber strand and four independent analog 4-20mA or 0-10VDC outputs. Each channel can be selected for 4-20mA or 0-10V signal protocols. The Receiver card is locally powered by a 22-56VDC source. The Receiver Card provides LED indicators to display power, alarm, and fiber link status.

**Note:** The Receiver can be modified for use with 0-5VDC or 0-20mA signals. Consult factory.

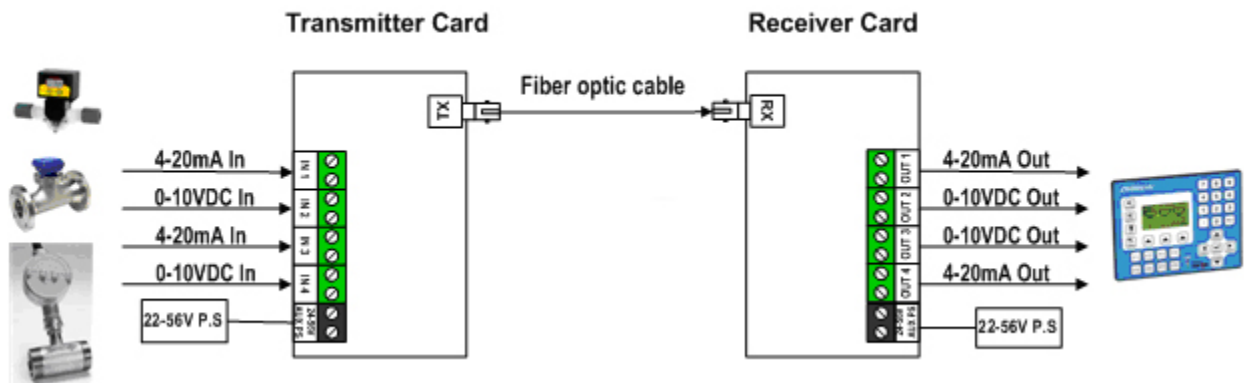

4-20mA/0-10VDC Analog System Diagram

### Installation

The Fiber Optic Link 4-20mA card can be installed into any RLH card housing. All electrical and fiber optic connection are made directly onto the card.

**Connect fiber optic cable.** Fiber Optic Link Contact Closure Cards are equipped with a optical connector. Connect fiber between the Transmitter card marked “TX” and Receiver card marked “RX” optics. Fiber cable should always be routed loosely avoiding tight bends.

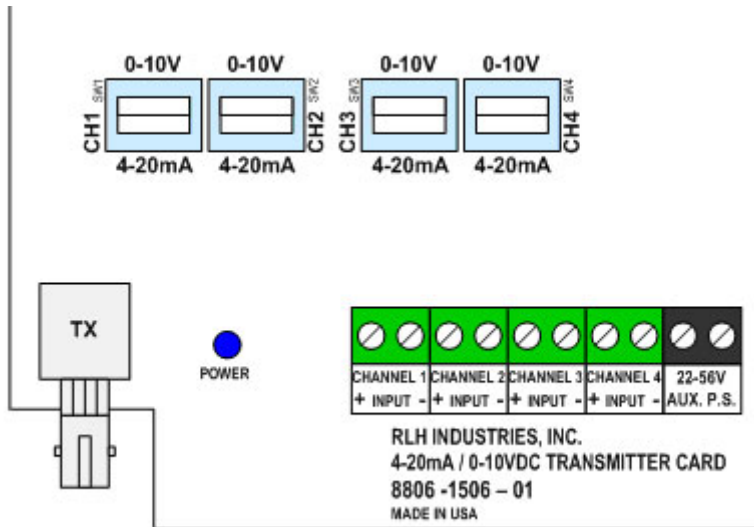

**Transmitter Card Connectors**

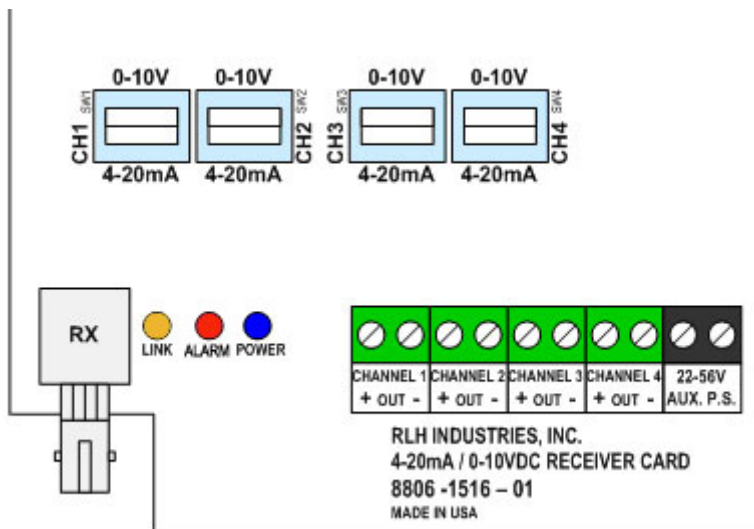

**Receiver Card Connectors**

**Connect wire pair.** The wire pair from the sensor or controller equipment connects to the Transmitter green screw-down terminals on the Transmitter Card. Observe polarity on the inputs.

**Connect Power.** Connect a 22-56VDC power source to the black “AUX. P.S.” screw-down terminal on both cards. The power input is not polarity sensitive.

### **Configuration**

The Transmitter card can accept 0-10VDC or 4-20mA inputs and the Receiver can output 0-10VDC, 2-10VDC, or 4-20mA signals. Each channel can be set individually. Use the set up below:

#### **4-20mA in and 4-20mA out (Factory Setting):**

Set switch labeled CH1, 2, 3 or 4 (SW1,SW2,SW3,SW4) on both cards to 4-20mA. On Transmit card, Range Limit jumper (J3,J4,J5,J6) is set to "B".

#### **0-10VDC in and 0-10VDC out:**

Set switch labeled CH1, 2, 3 or 4 on both cards to 0-10V. On Transmit card, Range Limit jumper is set to "A".

#### **4-20mA in and 0-10VDC (or 2-10VDC) out:**

Set switch labeled CH1, 2, 3 or 4 to 4-20mA on Transmit card, then set Range Limit jumper to "B".

Set switch CH1, 2, 3 or 4 to 0-10VDC on Receive card.

**Note:** By changing Transmit card's Range Limit jumpers to the "A" position, the Receive card's output is 2-10VDC instead of 0-10VDC.

#### **0-10VDC in and 4-20mA out:**

Set switch labeled CH1, 2, 3 or 4 on Transmit card to 0-10VDC, Range Limit jumper is set to "A"

Set switch CH1, 2, 3 or 4 to 4-20mA on Receive card.

**Troubleshooting**

If trouble is encountered, verify all installer connections, signal and voltage levels. If trouble persists, replace the unit and retest. If technical assistance is required, contact RLH Industries, Inc. Technical support department: (714) 532-1672 (6 am to 6 pm- PST), or for after hours, weekends and holidays call (714) 366-2503 or (714) 457-5740.

**Warranty Repair**

RLH Industries, Inc. Fiber Optic Link products have an unconditional lifetime warranty. If a unit needs repair, call the RLH Customer Service department for a Return Material Authorization (RMA) number and return the defective unit with the RMA number, freight prepaid, along with a brief description of the problem. As specified in our warranty RLH will repair and return the unit at no charge to the customer. If an out-of-service condition exists, a replacement unit can be obtained; however, a purchase order number will be required to ensure return of the replacement unit.

**Specifications**

Transmission method	Frequency modulated light via two optical fibers Multimode: 850nm Single-mode: 1310nm
Maximum Fiber Loss / Distance*	Multimode: 6dB / 0.6 miles (1km) Single-mode: 8dB / 9 miles (15km) SM Long Haul: 26dB* / 37 miles (60km) ; *-8dB minimum *Distance is equated using industry standard fiber and connector attenuation.
Fiber Type	Multimode: 62.5/125µm, 50/125µm ; Single-mode: 8-9/125µm
Fiber Connector Types	ST or SC
Wire Connector	Screw clamp, 16-26 AWG
Input 1-4 (TX Card)	4-20mA current loop or 0-10VDC
Output 1-4 (RX Card)	+/- 2% accuracy 500 Ohm maximum loop resistance
Response Time	10 msec
Surge Protection	PTC thermistors, zener diodes and varistors
Power Requirements	TX Card: 22-56VDC, 2.5W max (12V power option: 9-36VDC) RX Card: 22-56VDC, 7.5W max
Powering Method	Local DC
Operating Temperature	-40° to +158° F (-40° to +70° C), 95% non-condensing
Dimensions	7"x4"x1"